

Hei-VAP Value

Hei-VAP Advantage



Operating Instructions



Part of Thermo Fisher Scientific

Belgique / België tél 056 260 260
España tfno 91 380 67 10
France tél 03 88 67 53 20
Italia tel 02 953 28 258
Netherlands tel 020 487 70 00
Portugal tel 21 425 33 50
Suisse / Switzerland tél 056 618 41 11

fax 056 260 270
fax 91 380 85 02
fax 03 88 67 11 68
fax 02 953 27 374
fax 020 487 70 70
fax 21 425 33 51
fax 056 618 41 41

be.fisher@thermofisher.com
es.fisher@thermofisher.com
fr.commande@thermofisher.com
it.fisher@thermofisher.com
nl.info@thermofisher.com
pt.fisher@thermofisher.com
info.ch@thermofisher.com

www.be.fishersci.com
www.es.fishersci.com
www.fr.fishersci.com
www.it.fishersci.com
www.nl.fishersci.com
www.pt.fishersci.com
www.ch.fishersci.com

Translation of the original operating instructions.

The operating instructions must be read prior to the initial start-up for your safety and ease of use! Follow safety instructions to prevent unnecessary accidents from occurring associated with misuse of product!
Store for future use in a safe location!
This documentation is not subject to any modification service!

Table of contents

1	About this Document.....	1
1.1	Versions references.....	1
1.2	About this manual.....	1
1.2.1	Reference documents.....	1
1.2.2	Icons and symbols.....	2
2	Basic safety instructions.....	5
2.1	General Safety Instructions	5
2.2	Intended use.....	5
2.3	Improper Use.....	5
2.4	Use in explosion-prone areas	6
2.5	Responsibilities of the operator	6
2.6	Responsibilities of the operating personnel	6
2.7	Qualifications of Personnel.....	7
2.8	Safety Conscious Working.....	7
2.9	Safety devices on the equipment	7
2.10	Signs on the equipment	8
2.11	Remaining hazards	8
3	Unit Description	11
4	Set-up and Start-up.....	12
4.1	Scope of delivery	12
4.2	Transport	14
4.2.1	Removing the transportation safety device	14
4.2.2	Attaching the transportation protection device before packing	14
4.3	Setting up the basic unit	15
4.4	Start-up	15
4.4.1	Installing the heating bath	15
4.4.2	Fill the heating bath	16
4.4.3	Offsetting the heating bath.....	16
4.4.4	Heating bath set-up when using Rotacool	16
4.4.5	Connect the base unit.....	17
4.4.6	Operating the lift	19
4.5	Assemble glassware sets.....	19
4.5.1	Install the condenser mounting (G3-G6).....	20
4.5.2	Install the vapor tube	21
4.5.3	Install the condenser.....	23
4.5.4	Mount the vertical condenser (G3-G6) in the condenser bracket.....	25
4.5.5	Install the evaporator flask.....	26
4.5.6	Setting the evaporator flask inclination	27
4.5.7	Setting the immersion depth of the evaporator flask.....	28
4.5.8	Release the evaporator flask from the vapor tube	29
4.5.9	Insert the inlet tube	30
4.5.10	Assemble the inlet tube	30
4.5.11	Assemble the collecting flask.....	31
4.5.12	Connect the cooling medium (except G5).....	31
4.5.13	Connect the vacuum.....	32

- 4.6 Feed the distilled material 37
- 4.7 Ventilate manually 37
- 4.8 Assemble / connect accessories 38
- 4.9 Operating the control panel 40
- 5 Switching on the base unit.....44**
- 6 Operation of the Hei-VAP Value45**
 - 6.1 Set the rotation speed 45
 - 6.2 Setting the heating bath temperature..... 46
 - 6.3 Error messages..... 46
- 7 Operation of the Hei-VAP Advantage47**
 - 7.1 Setting the heating bath temperature..... 48
 - 7.1.1 Select heating bath medium 48
 - 7.1.2 Setting the heating bath temperature..... 49
 - 7.2 Set the rotation speed 49
 - 7.3 Calculating the boiling temperature (Hei-VAP Advantage) 50
 - 7.4 Timing functions 51
 - 7.4.1 Timer 51
 - 7.5 Error messages..... 51
 - 7.6 Upgrading 51
- 8 Errors and Troubleshooting.....52**
 - 8.1 General errors 52
 - 8.2 Additional conditions 53
 - 8.3 Hei-VAP Value 54
 - 8.4 Hei-VAP Advantage..... 55
- 9 Maintenance, cleaning, service.....57**
 - 9.1 Maintenance 57
 - 9.1.1 Resetting the maximum temperature limiter 57
 - 9.1.2 Evacuate the heating bath 58
 - 9.1.3 Readjust the vacuum seal (glassware set G6)..... 58
 - 9.2 Replacing the fuses 59
 - 9.3 Cleaning..... 60
 - 9.4 Service 60
- 10 Dismantling, storage, disposal61**
 - 10.1 Disassembly 61
 - 10.1.1 Remove the Woufff bottle 61
 - 10.1.2 Disconnecting the coolant / vacuum 62
 - 10.1.3 Remove the heating bath..... 62
 - 10.2 Storage..... 62
 - 10.3 Disposal..... 62
- 11 Accessories, spare parts63**
 - 11.1 Glass devices 63
 - 11.2 Accessories..... 67

12	Appendix	68
12.1	Technical data	68
12.2	Technical data o the vacuum box Hei-VAP.....	70
12.3	Solvent data.....	71
12.4	EC Declaration of Conformity	73
12.5	Warranty Statement	74
12.6	Declaration of non-objection	75

1 About this Document

1.1 Versions references

Version	Modification
1.0	07/2009

Versions references

1.2 About this manual

These instructions use icons and notes that will help simplify the process of locating information quickly. Read the explanations regarding these notes and icons in the following section.

Notes regarding this manual

Please read the safety guidelines and warnings in these instructions very carefully to ensure safe operation of the product. You will find the safety instructions in chapter 2. Warnings may be found in the introductions throughout of the chapters and prior to instruction sections.

Heidolph Instruments GmbH & Co. KG has the copyright for images and texts.

1.2.1 Reference documents



Information for the Heidolph vacuum pumps Rotavac valve control and Rotavac valve tec, along with the Vac control automatic controller are contained in a separate operating instruction # 01-005-004-80.

Information regarding the Heidolph emission condensate cooler vacuum pumps, Rotavac vario control and Rotavac vario tec are contained in a separate operating instruction, # 01-005-004-90-0.

Reference documents

1.2.2 Icons and symbols

Warnings

Warnings

The following symbols and signal words will be continuously used in this documentation. The combination of icon and a signal word classifies the respective safety instruction. The symbol can vary according on the type of risk.



	Icon	Designation
Death	RISK 	This signal word must be used, if death or irreversible health impairments may develop when the non-compliance of operator regarding the hazard warning.
Injury + property damages	WARNING 	This signal word points to injuries and property damages, including injury, accident and health risks.
	WARNING 	This signal word provides a reference to the risk of property damages. In addition, there is a low risk of injuries.
No damages	CAUTION	This signal word may only be used, if health risks cannot develop. It warns of malfunctions and is presented without an icon, since the degree of the risk to operator is low.
	IMPOR- TANT	This signal word points to operation simplifications and cross-references. It excludes any risks of property damages or risks of injuries and is therefore without an icon.

Table 1-1: Identification of warnings

Structure of warnings

Structure of warnings











RISK **The type and source of the risk is located here!**
 The potential consequences, if actions are not taken to prevent the risk are listed here.
 → The action to prevent the risk is listed here.



WARNING **Risk of injury based on disregarding the safety icons!**
 Risks exist here based on disregarding the warnings on the device and in the operating instructions.
 → Observe warnings.

The following specific safety icons in correspondence with BGV A8 regulations will be used at the respective text locations of these operating instructions and require special attention depending on the combination of the signal word and icon:











Mandatory signs

Icon	Explanation	Icon	Explanation
	Observe information		Use eye protection
	Follow additional information		Use hand protection
	Use protective clothing		Use foot protection
	Pull the power plug after use Pull the power plug prior to opening the housing		Use ear protectors

Mandatory signs

Table 1-2: Icons and symbols

Warning signs

Icon	Explanation	Icon	Explanation
	Warning of a dangerous location		Warning of a risk of entanglement
	Warning of a hot surface		Warning of dangerous electric voltage
	Warning of hand injuries		Warning of vacuum
	Warning of automatic start		Warning of slippery conditions
	Warning of explosive materials		Warning of explosion-risk area

Warning signs

Table 1-3: Icons and symbols

Prohibitory signs

Prohibitory signs





Icon	Explanation	Icon	Explanation
	Fire, open flame and smoking prohibited		Prohibition for people with metal implants
	Prohibition for persons with a pacemaker		extinguishing with water is prohibited
	Depositing or storing is prohibited		

Table 1-4: Icons and symbols

Other icons and symbols

Other icons and symbols

Icon	Use	Explanation
✓	Prerequisite	This must be met prior to following any operating instructions
➔	Operating instructions	You must do something here
1. 2.	Operating instructions, multi-step	Operating instructions must be performed in the listed sequence. Deviations from the specified sequence may result in damages of the equipment and in accidents
Actual	result	The result of a previous activity is described when indented
• –	Listing, two-tiered	Something is listed here
(see chapter 2)	Cross-reference	References for images, tables, other chapters or other instructions.
Example	Switch description	Emphasizing the description of switches/buttons
	Note	Important information for the understanding of the equipment or for improved operation sequences

Table 1-5: Icons and symbols

Images

Item numbers in the images in the text are conveyed in parentheses. If no image number is listed, the item number refers to the image/graphic directly above the text. If the reference is made to another image/graphic, the image number is specified accordingly, i.e. (Fig. 4-1 (11)).

2 Basic safety instructions

The rotary evaporator is constructed according to current state of the art methods and accepted safety regulations. However, risks still exist during the installation, operation and maintenance of the product.

Basic safety instructions

→ Observe safety instructions and warnings.

The basic safety instructions in this chapter are supplemented in the following chapters of the operating instructions by concrete warnings. These warnings will precisely explain how you must conduct yourself to protect yourself, other persons and objects from injuries or damages.

These instructions are for the following evaporator models, the Hei-VAP Value and Hei-VAP Advantage rotary evaporator.

→ Always keep the instructions available.

→ Pass the instructions on to subsequent owners.

2.1 General Safety Instructions

The rotary evaporator may only be used

General Safety Instructions

- in an operational condition consistent with full functionality of equipment,
- for the intended use described in section 2.2,
- if the operator has the required safety protection and awareness to hazards,
- if the instructions of these operating instructions are observed.

Malfunctions, especially those that may affect safety, must be repaired immediately!

2.2 Intended use

Hei-VAP Value and Hei-VAP Advantage are rotary evaporators for:

Intended use

- distillation or evaporation of solvents
 - purification of chemicals, substances, mixtures and preparations
 - processing reaction batches
 - drying of powder
- If the equipment is used in corrosive atmospheres, the service life of the equipment will decrease based on concentration, volumes, and frequency of exposures to these corrosive materials, for example concentrated Hydrochloric Acid (HCl).

Any other or additional use is considered not to be in accordance with its designated use.

The manufacturer is not liable for damage resulting from this action.

The operator alone carries the responsibility to comply with the intended use outlined above. Observing these instructions and all references, especially safety instructions, as well as the adherence to inspection and maintenance requirements (see chapter 9.1) are a part of the designated use of Hei-VAP rotary evaporator.

2.3 Improper Use

- Applying excess pressure to the equipment is not permitted and can result in explosion of the system.
- Do not use the equipment in explosion-prone areas based on local ordinance and compliance of general laboratory equipment. The equipment is not protected against explosions in excessively volatile and poorly ventilated environments.

Improper Use

2.4 Use in explosion-prone areas

Use in explosion-prone areas

Do not use the equipment in explosion-prone areas. The equipment is not protected against explosions. It is not equipped with Ex or ATEX protection.

2.5 Responsibilities of the operator

Responsibilities of the operator

- Only operate the equipment in perfect condition, contact a certified Heidolph Service representative if equipment does not meet the outlined conditions for operation.
- Verify that only qualified personnel operate the equipment with the appropriate personal protective protection.
- Verify that personnel have received safety instructions for working responsibly and safely in the laboratory.
- Verify that the rotary evaporator is set up in a safe and suitable location.
- Verify that the basic device is only plugged to or unplugged from the heating bath if the main switch is switched off and/or the main power supply is disconnected.

Depending on the media (chemicals) used:

- Verify that the set up and the operation are only within the designated buildings with the proper equipment for laboratories.
- Verify that the rotary evaporator is only operated in conjunction with a ventilation system (refer to DIN EN 14175 and DIN 12924).
 - Ventilation system:
 - at least 10 times the air exchange
 - monitored for malfunctions

2.6 Responsibilities of the operating personnel

Responsibilities of the operating personnel

- Verify that the distillation material can be evaporated safely and that the distillation residue is not explosive.
- Verify that work using an open flame is not conducted in the surroundings of the rotary evaporator (explosion risk).
- Verify that the flow rate of < 1 m/s is guaranteed when suctioning liquids that contain combustible materials (electrostatic charge; ignition risk).
- Verify that gases of explosion group IIC do **not** occur in materials or chemical reactions, such as hydrogen.
- Verify that equipment that is an emission or radiation source (electromagnetic waves) for the frequency range ($3 \cdot 10^{11}$ Hz to $3 \cdot 10^{15}$ Hz) is not operated or attached.
- Verify that equipment that is an emission or radiation source for ionizing waves or that is within the ultrasound range is not operated or attached.
- Verify that adiabatic compression and shock waves do not occur (shock wave ignition).
- Verify that the use of substances with the risk of an uncontrolled release of energy associated with a rise in pressure is prohibited (exothermic reaction; self-ignition of dust).
- Verify that the glass surfaces are wiped off by using only damp cloths.
- Wear suitable protective clothing for activities on the rotary evaporator a (with goggles and gloves, if necessary).
- Avoid pressure on the LCD screen, it is not intended to be a touch screen interface.
- Verify that the maximum excess pressure of the coolant equals no more than 1 bar in the condenser.
- Verify that the basic device is only plugged to or unplugged from the heating bath if the main switch is switched off and/or the main power supply is disconnected.

2.7 Qualifications of Personnel

The target group of the rotary evaporator is qualified personnel only. The rotary evaporator may only be used by personnel that have been trained in the proper operation by qualified personnel determined in accordance with the internal safety regulations of the facility in which the rotary evaporator is operated.

Qualifications of Personnel



This user's manual and all safety instructions must be observed, read and understood by all personnel working on the fixture (in particular in reference to the safety instructions).

2.8 Safety Conscious Working

Heidolph Instruments is not liable for personal injuries and / or property damages caused by an incorrect and improper usage of the rotary evaporator.

Safety Conscious Working

→ Observe the following regulations:

- Laboratory guidelines
- Accident prevention regulations
- Ordinance on Hazardous Substances
- Other generally accepted rules of safety engineering and occupational health
- Local regulations

2.9 Safety devices on the equipment

Heating bath

- Electronic and mechanical excess temperature protection
- Electronic temperature control

Safety devices on the equipment

Base unit

- Clamps to secure evaporation and receiving flasks
- Adjustable immersion depth of the evaporator flask
- The evaporator flask may be lifted from the heating bath, if required
- Overcurrent protection on lift motors (only Hei-VAP Advantage and Hei-VAP Precision)
- Thermal overtemperature protection on the drive motor
- Torque restrictor

Glassware set

- Borosilicate glass
- Screw connectors on the connections
- Support rod and clamp for glassware sets G3, G5 and G6

Optional

- Surlyn coating (Safecoat coating for glassware set G5) of the glassware parts
- Protective hood
- Protective shield

2.10 Signs on the equipment

Signs on the equipment



Sign	Designation
	Hot surface
	Risk of entanglement
	Model tag
	Fuse label (bottom of the device)

Table 2-1: Signs on the equipment

2.11 Remaining hazards

Remaining hazards

Obvious residual risks may still exist, despite all precautions! Residual risks can be reduced if the safety instructions for the intended use and the operating instructions are all observed!

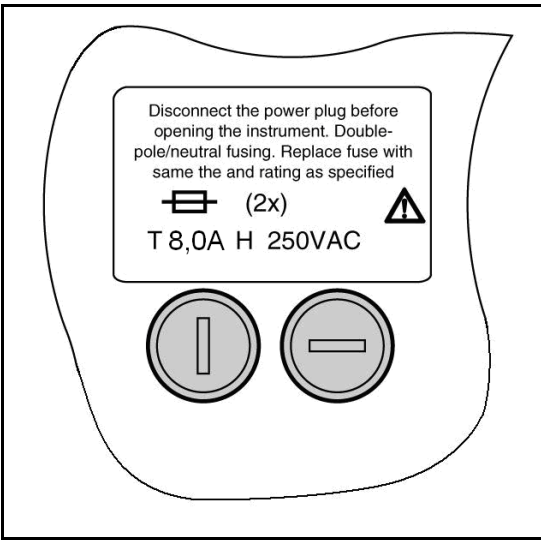

CAUTION

Unintentionally rotating drive!



Injuries to hands.

→ Verify that the rotation is displayed.



WARNING

Danger of slipping!



Risk of injury.

The floor near the machine may be dirty after the operation or during malfunctions in the machine. Water from the bath may spill or condensation from coolant may drip on to the floor near equipment.

→ Watch for contaminated areas and clean the floor, if necessary.

WARNING**Hot surfaces!**

Scalding and burns.

→ Let the heating bath and glass devices cool before handling.

**WARNING****Glass breakage!**

Cuts.



→ Work carefully.

**WARNING****Malfunctions!**

Risk of injury.

Malfunctions or operating conditions that may affect the safety of operating personnel require a shutdown of the equipment by disconnecting the power supplies.

→ A proper restoration of the normal state is required.

**WARNING****Unauthorized access is prohibited!**

Risk of injury.

Risks exist, if unauthorized personnel enter the danger zone of the evaporator.

→ The operator has to ensure that unauthorized persons (e.g. visitors) do not have any access to dangerous areas (service area, protected areas).

**WARNING****Risk of injury from operational noise!**

Hearing impairment from the continuous sound pressure level of the equipment may occur.

→ Protect against noise-induced hearing loss with ear protection.

**DANGER****Disregarding the danger, work and service area!**

There are risks due to electrical and mechanical energies, as well as specific residual risks.

Guarantee a safe distance of 800 mm around the evaporator components.

Do not deposit or store anything within the work and service area.

Accessories, chemicals or tools must be stored so that no risks arise for personnel.



**WARNING****Imploding glass devices!**

Serious injuries from shattering glass.



- Check glass devices for damages (stars, breaks, cracks, etc.)
- Only use perfect glass devices and replace all damaged glassware as soon as possible.



- Verify that the interior and exterior pressure variance equals no more than 2 bar.

**DANGER****Potential loss of life due to dangerous electrical voltage!**

Serious risk of injuries.



Residual electrical energy remains in the electrical wires, equipment and machines, when the evaporator is switched off.

- Inform operating personnel of outlets. Disconnect the sockets from the power source to completely de-energize.
- Work on the power supply must only be performed by an electrician. Switch off the power switch.
- Disconnect the evaporator from the power supply. Routinely check the electrical equipment (power lines) of the evaporator for any wear or fraying of wires.
- Replace burned or melted power lines. Routinely check all power cables for damages within the scope of maintenance and repair services.

Only disconnect the basic device with the heating bath if the device is de-energized. Unplug main power supply.

**DANGER****Risks of injuries and mortal danger when disregarding safety instructions and safe distances!**

Risk of injury.

Risks exist when disregarding safety instructions and the safe distance to the machine.

- Observe safety instructions and signs on the evaporator and in these operating instructions. Adhere to the corresponding safe distance to the equipment.

**DANGER****Danger of fire and explosions!**

Serious risk of fire and explosions.



A risk of fire and explosions exists in the vicinity of the evaporator. Fire, open flame and smoking are prohibited near the equipment.



- Flammable liquids may not be stored within the danger zone of the evaporator. A fire extinguisher must be kept near the equipment.
- Avoid potential ignition sources, such as ignitable atmospheres or reactions or electrostatic charges.
- Avoid exothermic reactions or the spontaneous ignition of dust.
- Avoid adiabatic compression and shock waves.
- Particular caution to reactions of explosion group IIC, in which hydrogen can develop.

3 Unit Description

Rotary evaporators Hei-VAP Value, Hei-VAP Advantage, Hei-VAP Precision serve the

Unit Description

- distillation or evaporation of solvents (chemicals)
- purification of chemicals, substances, mixtures and preparations
- processing reaction batches
- drying of powder

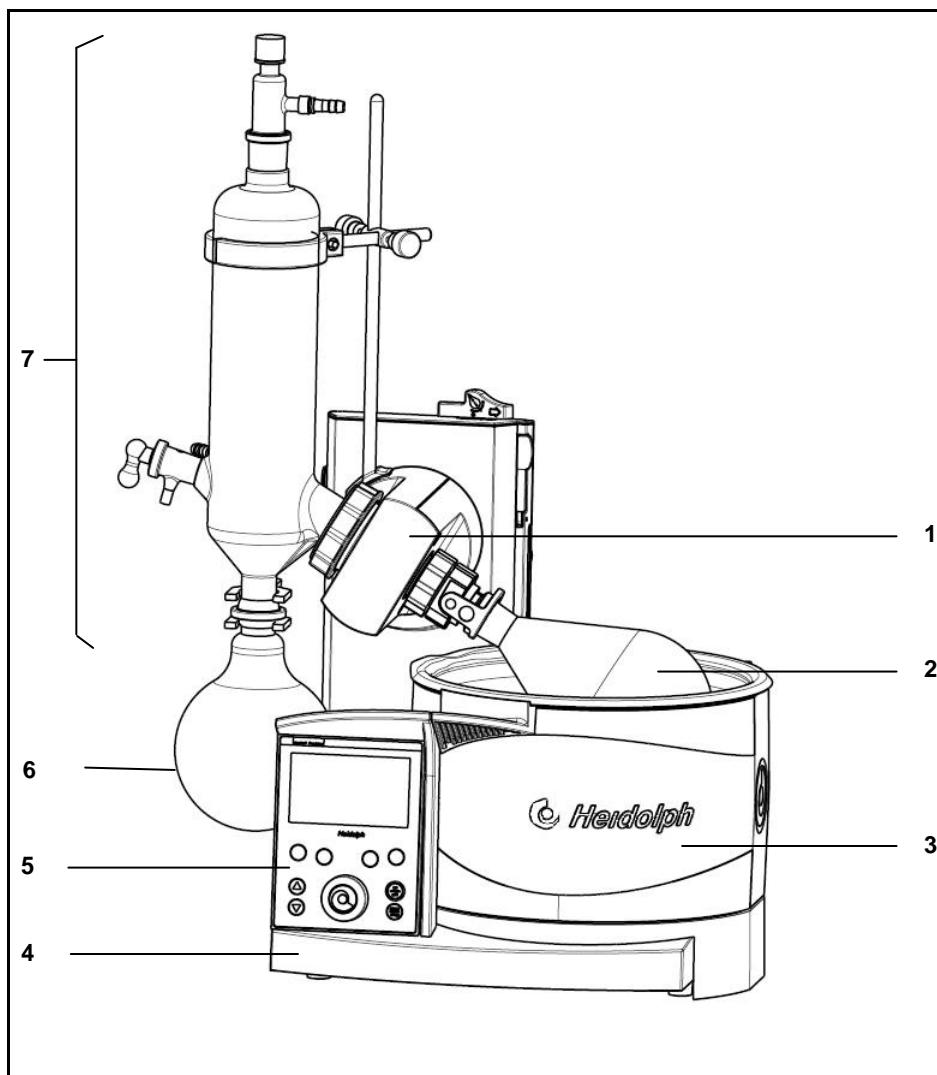

Figure 3–1: Rotary evaporator, here a Hei-VAP Precision with glassware set G3

- | | | | |
|---|--|---|-----------------|
| 1 | Drive unit with vapor tube and coupling clamp duct | 4 | Base unit |
| 2 | Evaporator flask | 5 | Control panel |
| 3 | Heating bath | 6 | Receiving flask |
| | | 7 | Condenser |

The solvent to be evaporated is present in the evaporator flask (2). Depending on the thermodynamic properties of the solvent, the solvent is evaporated by a suitably selected combination of the heating bath temperature (3) and the vacuum. The settings are made on the control panel (5) of the base unit (4). The drive unit (1) provides a rotation, which reduces the risk of boiling evaporation and accelerates the evaporation process by increasing the surface area of the solvent. The solvent vapor reaches the condenser (7) via the vapor tube, is condensed and then flows into the receiving flask (6).

4 Set-up and Start-up

4.1 Scope of delivery

	Description	Completion	Quantity	Hand lift truck (HL)		Motor lift (ML)	
				Standard	coated	Standard	coated
		Glassware set					
	Hei-VAP Value	G1 diagonal condenser	1	560-01100-00	560-01110-00		
or	Hei-VAP Value	G3 vertical condenser	1	560-01300-00	560-01310-00		
or	Hei-VAP Value	G5 cold trap	1	560-01500-00	560-01510-00		
or	Hei-VAP Value	G6 return condenser	1	560-01600-00	560-01610-00		
or	Hei-VAP Advantage	G1 diagonal condenser	1	561-01100-00	561-01110-00	562-01100-00	562-01110-00
or	Hei-VAP Advantage	G3 vertical condenser	1	561-01300-00	561-01310-00	562-01300-00	562-01310-00
or	Hei-VAP Advantage	G5 cold trap	1	561-01500-00	561-01510-00	562-01500-00	562-01510-00
or	Hei-VAP Advantage	G6 return condenser	1	561-01600-00	561-01610-00	562-01600-00	562-01610-00
or	Hei-VAP Precision	G1 diagonal condenser	1	563-01100-00	563-01110-00	564-01100-00	564-01110-00
or	Hei-VAP Precision	G3 vertical condenser	1	563-01300-00	563-01310-00	564-01300-00	564-01310-00
or	Hei-VAP Precision	G5 cold trap	1	563-01500-00	563-01510-00	564-01500-00	564-01510-00
or	Hei-VAP Precision	G6 return condenser	1	563-01600-00	563-01610-00	564-01600-00	564-01610-00

	Description	Quantity	Order No. Standard NS 29 / 32	Order No. NS 24 / 40
	Glassware set G1	1	513-00100-00	513-00140-00
or	Glassware set G3	1	513-00300-00	513-00340-00
or	Glassware set G5	1	513-00500-00	513-00540-00
or	Glassware set G6	1	513-00600-00	513-00640-00
or	Glassware set G1 coated	1	513-00110-00	513-00150-00
or	Glassware set G3 coated	1	513-00310-00	513-00350-00
or	Glassware set G5 coated	1	513-00510-00	513-00550-00
or	Glassware set G6 coated	1	513-00610-00	513-00650-00

Included with the equipment:

	Description	Quantity	Order number
	Vapor tube coupling clamp with swing clamp	1	23-09-03-01-03
	Tension spring	1	22-03-02-01-05
	PTFE 26 vacuum seal	1	23-30-01-01-30
	Clamping piece 26	1	23-30-01-05-31
	Operating instructions Hei-VAP Value / Hei-VAP Advantage	1	01-005-004-79
	Operating instructions Hei-VAP Precision	1	01-005-004-92
	Warranty / declaration of non-objection	1	01-006-002-58

	Description	Quantity	Order number
	Power cable (EC)	1	14-300-009-81
	Power cable for the US	1	14-300-009-82
	Power cable for GB	1	14-300-009-83
	Power cable for Switzerland	1	14-300-009-84

	Description	Quantity	Order No. Standard NS 29	Order No. NS 24
	Swing clamp	1	23-30-01-05-29	23-30-01-05-57

Table 4-1: Scope of delivery

Accessories

	Description	Quantity	Order number
	Upgrade kit Advantage Precision-HL	1	569-30009-00
	Upgrade kit Advantage Precision-ML	1	569-40009-00

Table 4-2: Accessories

- ➔ Unpack the rotary evaporator and check for completeness and any potential shipping damages.
- ➔ Inform the Service Department of Heidolph Instruments in case of any damages (see chapter 9.4).

4.2 Transport

Transportation safety device

The motor lift units have a transportation safety device, which must be removed prior to the initial start-up of the unit or reattached prior to the return shipment. This is very important in shipping any return or repair of motor lift unit to make sure transport lock is assembled.

A brief description of the procedure for removing and reattaching the transportation safety device may be found in the following.

The transportation safety device consists of three M5x8 screws and a connecting plate with holes for fixing the position.

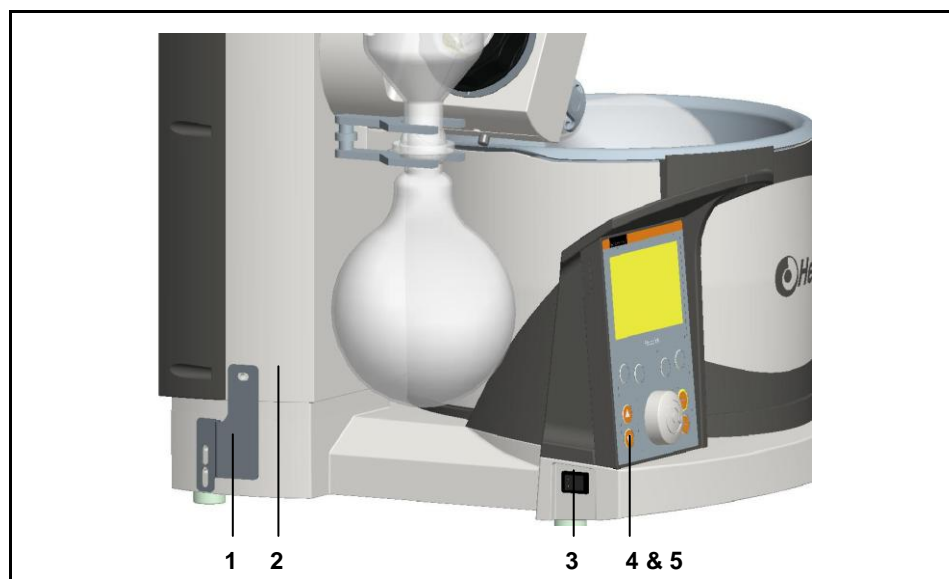

Figure 4-1: Transportation safety device

- | | | | |
|---|------------------------------|---|--------------------|
| 1 | Transportation safety device | 4 | Button – lift down |
| 2 | Front shell of lift | 5 | Button – lift up |
| 3 | Power switch | | |

4.2.1 Removing the transportation safety device

- ✓ All hose and cable connections to other devices, and the coolant/vacuum connection are disconnected.
 - ✓ Connect the unit and set the power switch (3) at on.
1. Remove the top screw (in the front shell of the lift (2)) and the lower screw of the transportation safety device (1) in the switched state. Never tighten in the top position!
 2. Remove the screws and the transportation safety device (1) and store.
 3. Move the hoist up by using the "lift up" (5) button. Switch the unit off and on.

4.2.2 Attaching the transportation protection device before packing

- ✓ All hose and cable connections to other devices and the coolant/vacuum connection are disconnected.

Connecting the unit

1. Continue pressing the lift position contact down when switching the unit on (this will suppress the "lift to the top when power off" function).
2. Move the hoist down by using the "lift down" (4) button.
Please pay attention to the lift-height stop!
3. Hold the transport safety device as shown in Image 4-1 and fix it with the screws M5x8 (3 pieces).

4. Switch off the unit.
5. Remove the plug.
6. Package the unit.

CAUTION**Vibrations and shocks!**

Damaging the housing and the mechanical system of the equipment.
 → Avoid vibrations and shocks.



- Carry the basic unit from below.

4.3 Setting up the basic unit

Chemicals may reach the atmosphere (via the pump) when handling hazardous materials and distilling solvents.

Where?

- Verify that harmful fumes or gases do not affect the operating personnel. The pump exhaust air must be channeled to an exhaust hood or condensate condenser.
- Verify that the interior and exterior pressure variance equals no more than 2 bar.
- Verify that the emergency stop for the power supply is always easy to reach.



Avoid setting up the rotary evaporator in corrosive atmospheres. This reduces the service life of the equipment.

CAUTION**Tilting the heating bath!**

Damaging the housing and risk of injuries.
 → Place the basic unit on a solid level surface with sufficient room.



- Select a level, solid, and heat resistant surface.

4.4 Start-up

4.4.1 Installing the heating bath

- ✓ The basic unit is located on a suitable place.

*Start-up
Installing the heating bath*

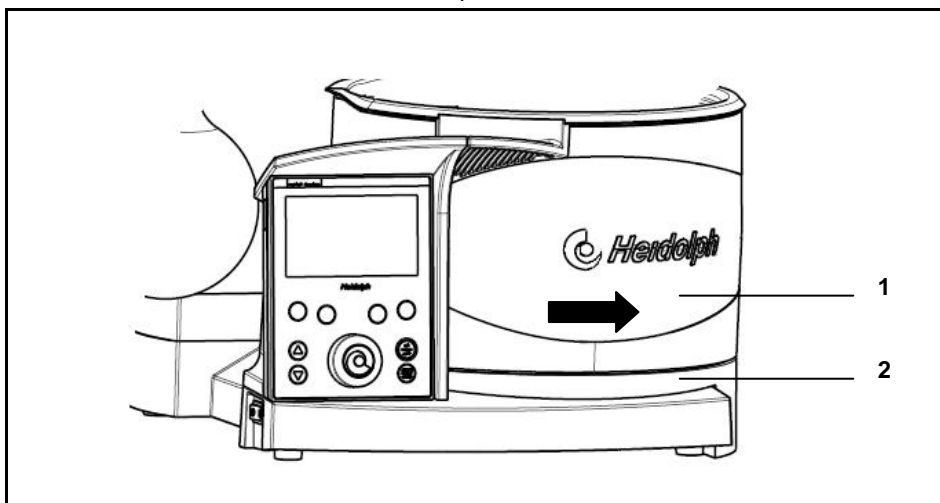

Figure 4-2: Heating bath

1 Heating bath

2 Base plate

1. Place the base plate (2) on the surface for the heating bath (1) into the provided rail, so that the heating bath cannot tilt.
2. Place the heating bath into the rails by its feet. Be careful that the heating bath connection points to the right rear.

4.4.2 Fill the heating bath

Fill the heating bath

The heating bath can be filled with various heat transfer fluids.



When using de-ionized or distilled water:

- ➔ Offset water with 0.2 % borax ($\text{Na}_2\text{B}_4\text{O}_7 \cdot 10 \text{H}_2\text{O}$) to prevent corrosion associated with these purified waters to the stainless steel of the heating bath.



The minimum-/maximum specifications in the heating bath refer to the liquid level when the evaporator flask is immersed.

1. Select a liquid suitable for your application, such as tap water, water-soluble polyethylene glycol or oil of a lower viscosity (40 cP) and flash point (observe the Safety Data Sheet) > 260 ° C.
2. Immerse the evaporator flask.
3. Fill the heating bath with the media of choice. The level should be within the minimum and the maximum marking in the heating bath.

4.4.3 Offsetting the heating bath

Offsetting the heating bath

It will be necessary to expand the distance of the heating bath to the drive unit when using large evaporator flasks or intermediate pieces between evaporator flasks and the vapor tube, such as bump flasks or foam brake flasks.

- ➔ Shift the heating bath including the base plate by the handle on the rail and position accordingly (Figure 4–2: Heating bath).



Location of the heating bath

- ➔ The base unit is located on a suitable surface. Verify that sufficient space (approx. 20 cm around the evaporator) and a solid seating are available in the shifting area.
- ➔ Verify a solid seating of the heating bath base and the bath.

4.4.4 Heating bath set-up when using Rotacool

Heating bath set-up when using Rotacool

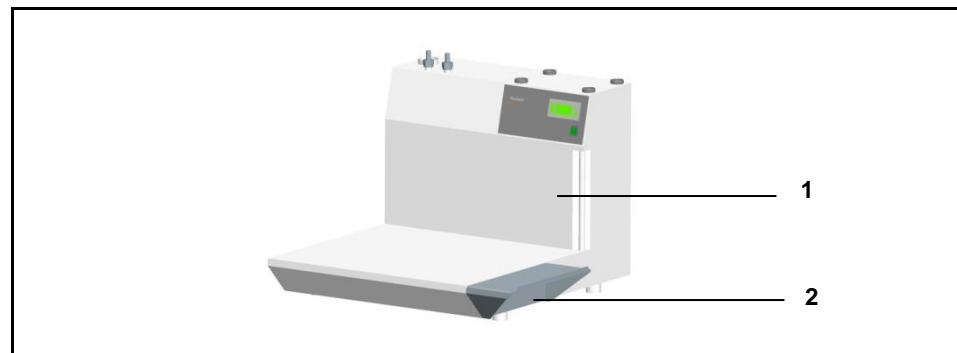

1 Rotacool

2 Rotacool extension plate



Location of the heating bath when using Rotacool

- The base unit is located on a suitable surface. Verify that sufficient space (approx. 20 cm around the evaporator) and a solid seating are available in the shifting area and the Rotacool.
- Verify a solid seating of the heating bath base and the bath as well as the Rotacool extension.

1. Place the two screws on the right side of the extension plate of the Rotacool. Contact a local Heidolph Distributor if using a previously purchased Rotacool before July, 2009 for proper attachments of the extension plate.
2. Check the extension plate (2) for proper seating.

4.4.5 Connect the base unit

Connect the base unit

CAUTION



Supply voltage and the voltage information on model tag do not match!

Damage due to incorrect voltage.

- Verify that the voltage specified on the model tag corresponds with the mains voltage.

Only disconnect the basic device with the heating bath if the device is de-energized. Unplug main power supply.



CAUTION



The drive unit and the heating bath may be switched on accidentally!

Injuring and burning hands.

Risk of entanglement

Injuries to hands.

- Verify that the power switch for the base unit and the heating bath is switched off by the rocker switch.



Country-specific equipment connection cable

The design of the equipment is equipped with a Euro connector (EN 50075) for 230/240 V by default, and with a US standard plug (NEMA Pub. No. WDI. 1961 ASA C 73.1 for a design for 120 V. 1961, page 8, 15 A 125 V).

The main power cable of the device has an integrated protective ground connection.

Please note if the appropriate equipment connection cable for your country was included and use it.

Equipment connection cable for:

- EU
- Great Britain
- Switzerland
- USA

In order to operate the equipment in a country with a different connector system, one can use approved adapters only or have a licensed electrician replace the plug with one suitable and approved for the power supply with protective ground connection.

Connection versions

The plug sockets are located on the back of the unit.

- ✓ The unit is switched off.
- ✓ The heating bath is installed on the base console.

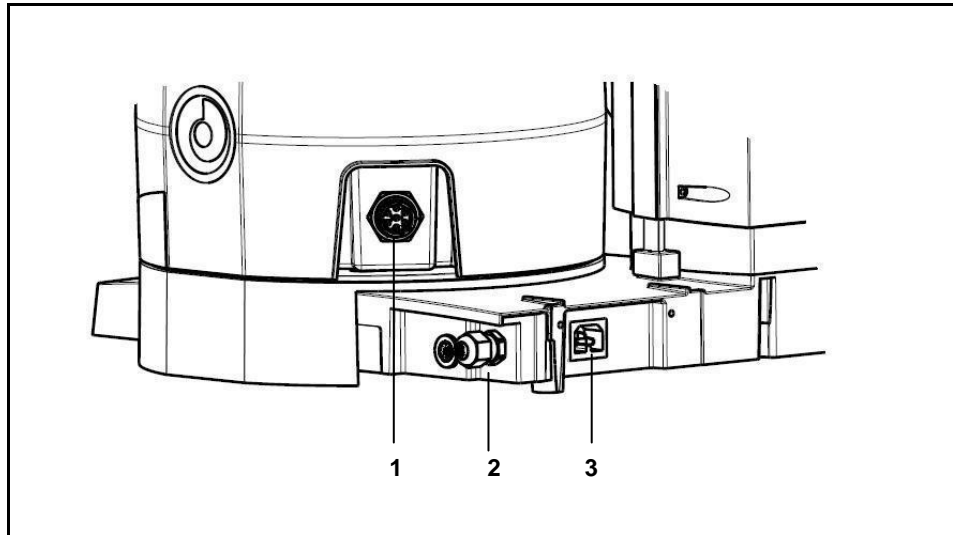

Figure 4-3: Connections

- 1 Heating bath unit plug
- 2 Heating bath connecting line (symbolically without a cable and connector)
- 3 Power supply connector

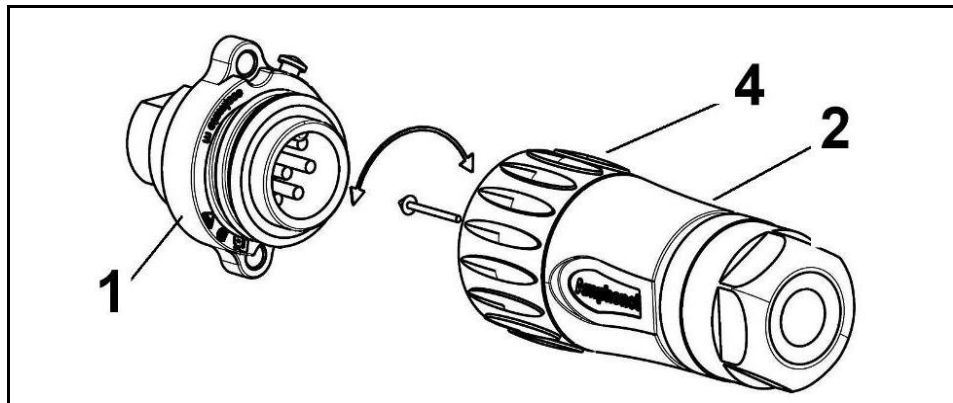

Figure 4-4: Heating bath connector

1. Plug the socket of the heating bath connecting cable (2) of the Hei-VAP base into the appropriate connector (1).
2. Plug the socket (2) with the cap nut (4) of the heating bath connecting cable (7-pin) into the heating bath:
 - Press the socket into the connector so that the locking stub fits into the groove.
 - Grab the socket (2) on the knurled nut (4) and turn the knurled nut clockwise to fix it.
3. Plug the power supply cable into the power supply plug on the back panel of the base unit.
4. Connect the power cable to the power supply.



WARNING

Glass breakage!

Serious injuries from shattering and breaking glass.



- Check glass devices for damages (stars, breaks, etc.).
- Only use perfect glass devices and replace all damaged glassware as soon as possible.
- Work carefully.



CAUTION

Unintentionally rotating drive!

Injuries to hands.



- Verify that the rotation is displayed.

4.5.1 Install the condenser mounting (G3-G6)

Install the condenser mounting

In order to protect the glassware sets with vertical condensers from accidentally tilting, they are supported by a condenser mounting and support rod.

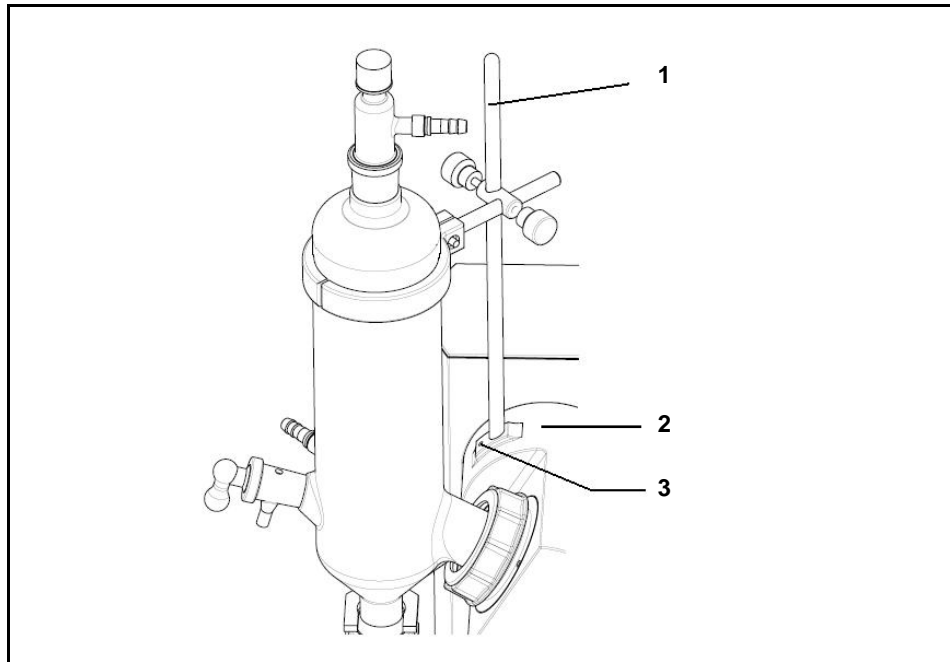

Figure 4-6: Install the condenser mounting

- 1 Support rod
- 2 Drive unit
- 3 Fastening screw - support rod



CAUTION

Unintentionally rotating drive!

Injuries to hands.



- Verify that the rotation is displayed.

WARNING**Risk of injuries due to retracting or entrapment!**

Risk of injury.

A risk of entanglement exists on the movable parts of the unit.

- Wear suitable protective clothing for activities on the rotary evaporator with goggles and gloves.



Attach the support rod (1) to the drive unit (2) via a fastening screw (3).

4.5.2 Install the vapor tube

The evaporator flask and the vapor tube are connected with the condenser and the rotation of the evaporator flask is made possible by the drive unit.

Install the vapor tube

WARNING**Glass breakage!**

Serious injuries from shattering and breaking glass.

- Check glass devices for damages (stars, breaks, etc.).
- Only use perfect glass devices and replace all damaged glassware as soon as possible.
- Work carefully.

**CAUTION****Unintentionally rotating drive!**

Injuries to hands.

- Verify that the rotation is displayed.

**WARNING****Risk of injuries due to retracting or entrapment!**

Risk of injury.

A risk of entanglement exists on the movable parts of the unit.

- Wear suitable protective clothing for activities on the rotary evaporator with goggles and gloves.



1. Remove the vapor tube from the packaging.

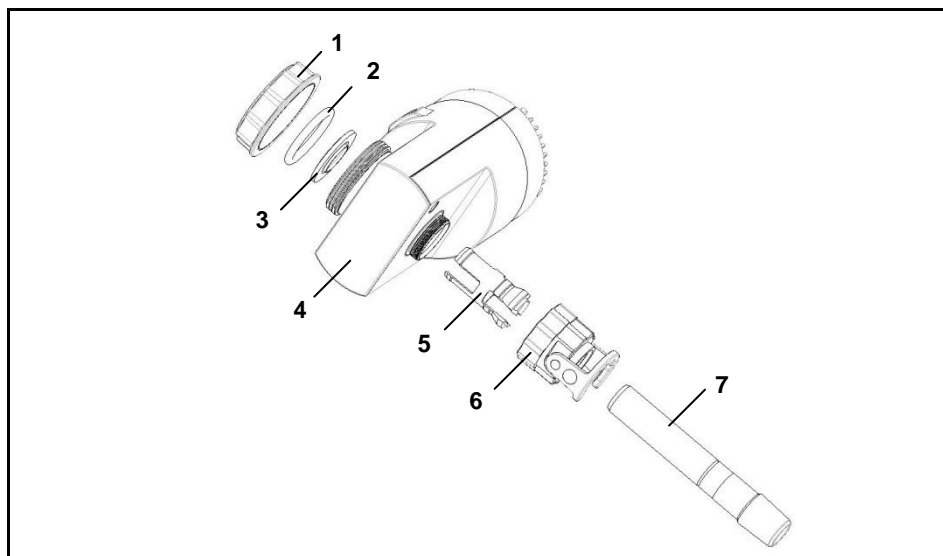

Figure 4-7: Install the vapor tube

2. Remove the threaded clamping screw (1) on the drive unit; remove the tension spring (2) and PTFE 26 vacuum seal (3).

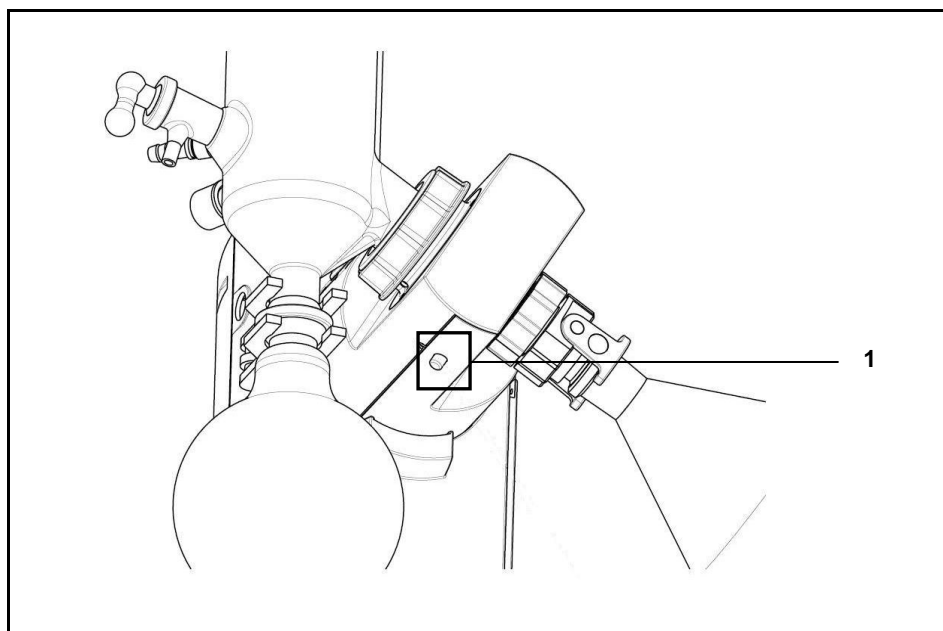
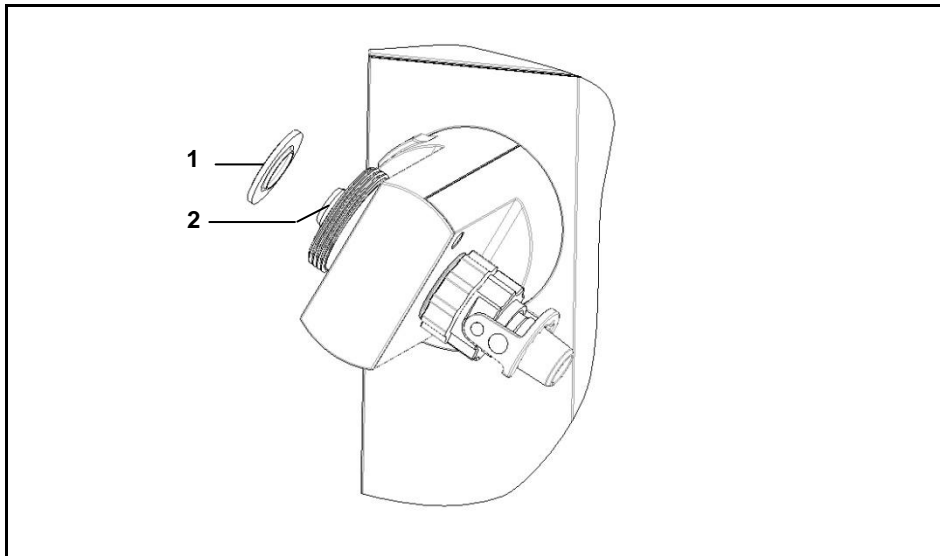

Figure 4-8: Locking button

Locking buttons

3. Continue to press the locking button (Figure 4-8 (1)).
4. Remove the screw coupling connection of the vapor tube (Figure 4-7 (6)) from the drive unit.
5. Pull out the clamping sleeve (Figure 4-7 (5)).
6. Push the vapor tube coupling clamp (Figure 4-7 (6)) and clamping sleeve (Figure 4-7 (5)) with the bead first to the vapor tube (Figure 4-7 (7)). Verify that the bead audibly snaps into the groove of the vapor tube (Figure 4-7 (7)).
7. Push the vapor tube (Figure 4-7 (7)) into the drive unit with the pre-assembled parts.
8. Continue to press the locking button (Figure 4-8 (1)).
9. Manually tighten the vapor tube coupling clamp (Figure 4-7 (6)) with the threaded connection of the motor drive (Figure 4-7 (4)) till a tight connection is made.



PTFE seal on the vapor tube

Figure 4-9: Placing the PTFE 26 vacuum seal on the vapor tube

- 1 PTFE 26 vacuum seal 2 Vapor tube



Do not bend the PTFE 26 vacuum seal or scratch it with pointed fingernails.

10. Push the PTFE 26 vacuum seal (1) onto the vapor tube (2) with the sealing lip in front (labeling on the **drive side** in the direction of the drive unit).

4.5.3 Install the condenser

- ✓ The threaded clamping screw is removed from the drive head.
- ✓ Spring is removed from the drive head.
- ✓ The vapor tube is installed on the drive.
- ✓ PTFE 26 vacuum seal is installed on the vapor tube.

Install the condenser

WARNING

Glass breakage!

Serious injuries from shattering and breaking glass.



- Check glass devices for damages (stars, breaks, etc.).
- Only use perfect glass devices and replace all damaged glassware as soon as possible.



- Work carefully.



CAUTION

Unintentionally rotating drive!

Injuries to hands.

- Verify that the rotation is displayed.





WARNING

Risk of injuries due to retracting or entrapment!



Risk of injury.

A risk of entanglement exists on the movable parts of the unit.

➔ Wear suitable protective clothing for activities on the rotary evaporator with goggles and gloves.

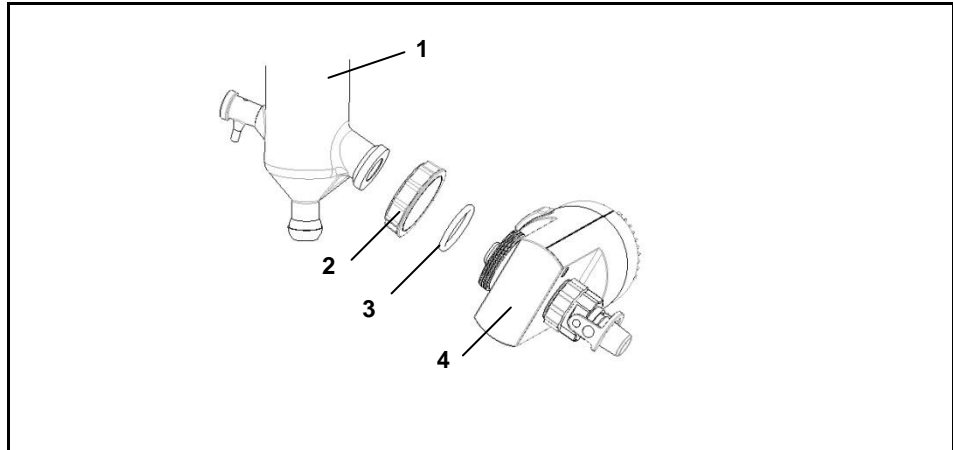

Figure 4-10: Assemble the glassware set (the example here is glassware set G1)

- | | | | |
|---|-------------------------|---|----------------|
| 1 | Condenser | 3 | Tension spring |
| 2 | Threaded clamping screw | 4 | Drive unit |

1. Version **glassware sets G1 and G3:**

- Push the threaded clamping screw (2) over the condenser flange.
- Push the spring (3) over the condenser flange.
- Attach the condenser (1) to the drive unit (4) with the clamping screw.

2. Version **glassware set G5 (depending on coolant):**

- Push the threaded clamping screw (2) over the cold trap jacket flange.
- Push the spring (3) over the cold trap jacket flange.
- Screw the cold trap jacket with the threaded clamping screw to the drive unit.
- Insert the o-ring in the sealing groove of the cold trap jacket.
- Insert the PTFE centering ring in the cold trap jacket and insert the cold trap insert (cold finger).

The flange is suctioned compressed by the vacuum and the system is closed vacuum-tight by the inserted o-ring.

3. Version **glassware set G6 (condenser for return flow distillation):**

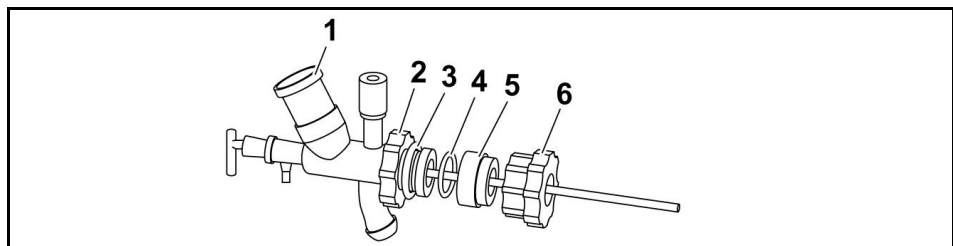

Figure 4-11: Glassware set G6

- | | | | |
|---|---------------------|---|--------------------------|
| 1 | Center piece | 4 | Gasket G6 |
| 2 | Threaded connection | 5 | G6 intermediate part (5) |
| 3 | Tension spring | 6 | G6 threaded coupling |

- Push the threaded connection (2) over the condenser flange.
- Push the spring (3) over the condenser flange.
- Screw the G6 (6) gland on the drive head (Figure 4–10 (4)).
- Insert the G6 intermediate part (5) with seal G6 (4) into the gland G6 (6).
- Screw the center piece (1) with the screw (2) on gland G6 (6).
- Insert the condenser in the upper cut on the center piece (1).

4.5.4 Mount the vertical condenser (G3-G6) in the condenser bracket

This step is omitted for horizontal condensers (G1).

- ✓ The support rod is installed.

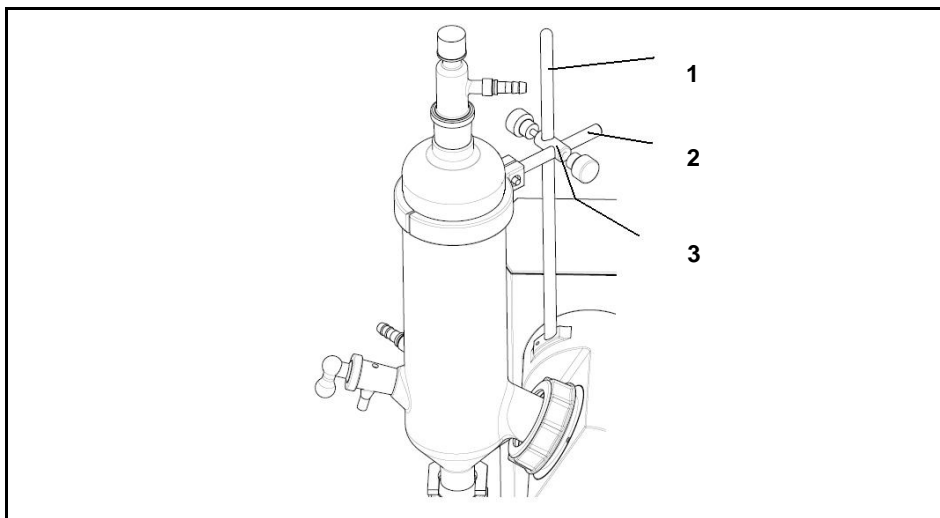

Condenser mounting

Figure 4–12: Condenser bracket (Glassware set G3 and G6)

- | | | | |
|---|-----------------|---|-----------------|
| 1 | Support rod | 3 | Boss head clamp |
| 2 | Condenser clamp | | |

Version **glassware set G3 and G6:**

1. Push the boss head clamp (3) onto the support rod (1) and position with the clamping screw.
2. Place the condenser clamp (2) around the condenser and attach on the support rod by using the clamping screw.

- Position the support rod with Allen screws (also refer to chapter 4.5.1).

Version **glassware set G5** (depending on coolant):

- Completely place the cold trap bracket into the lateral hole of the boss head clamp (2).
- Lock with the clamping screw.
- Place the cold trap bracket on the cold trap jacket.
- Position the cold trap jacket with the tension band on the cold trap bracket.
- Position the support rod (1) with an Allen screw (also refer to chapter 4.5.1).

4.5.5 Install the evaporator flask



WARNING

Glass breakage!

Serious injuries from shattering and breaking glass.



- Check glass devices for damages (stars, breaks, etc.).
- Only use perfect glass devices and replace all damaged glassware as soon as possible.
- Work carefully.



CAUTION

Unintentionally rotating drive!

Injuries to hands.

- Verify that the rotation is displayed.



WARNING

Risk of injuries due to retracting or entrapment!

Risk of injury.

A risk of entanglement exists on the movable parts of the unit.

- Wear suitable protective clothing for activities on the rotary evaporator with goggles and gloves.



Install the evaporator flask

- Install the evaporator flask with a permanent flask clamp on the vapor tube.

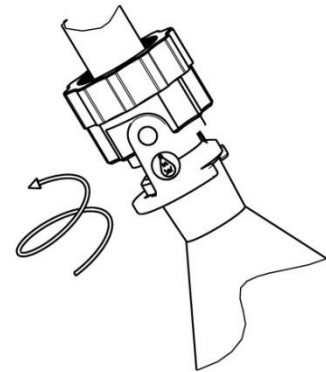
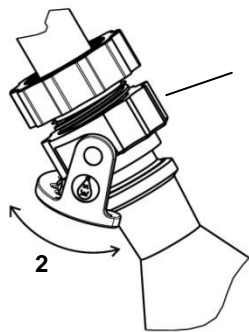

Figure 4-13: Flask clamp (swing clamp)

1 Jacknut

2 Swing clamp



The correct seating of the swing clamp on the flange of the evaporator flask must be observed!

4.5.6 Setting the evaporator flask inclination

The inclination of the evaporator flask can be set by turning the drive unit.

Setting the evaporator flask inclination

CAUTION



Unintentionally rotating drive!

Injuries to hands.
→ Verify that the rotation is displayed.



WARNING



Risk of injuries due to retracting or entrapment!

Risk of injury.
A risk of entanglement exists on the movable parts of the unit.
→ Wear suitable protective clothing for activities on the rotary evaporator with goggles and gloves.

WARNING



Glass breakage!

Serious injuries from shattering and breaking glass.
→ Check glass devices for damages (stars, breaks, etc.).
→ Only use perfect glass devices and replace all damaged glassware as soon as possible.
→ Work carefully.

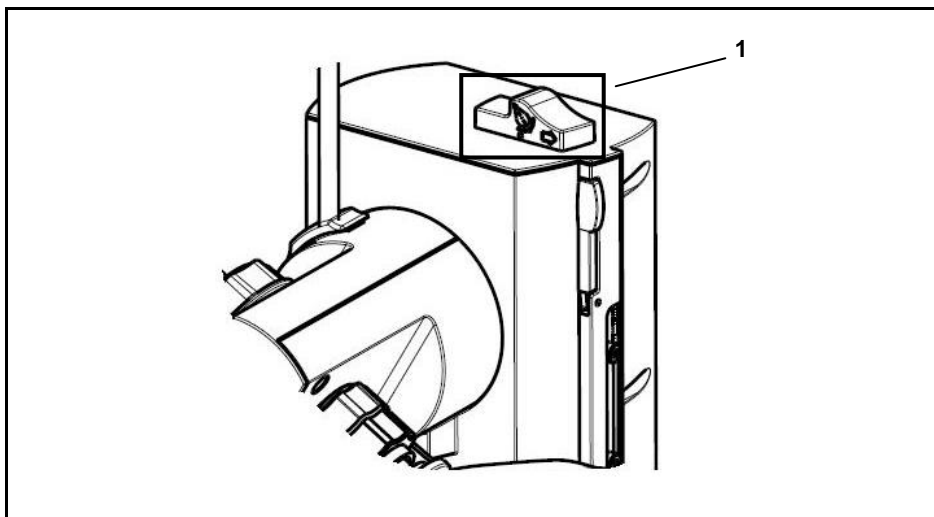

Evaporator flask inclination and immersion depth

Figure 4-14: Evaporator flask inclination / immersion depth

1. Grasp the condenser with the left hand.
2. Unlock the locking device (1) at the lift column toward the right by applying pressure with your right hand.
3. Set the evaporator flask inclination by carefully swinging the condenser.
4. Position the locking device by releasing and snapping it in.

4.5.7 Setting the immersion depth of the evaporator flask



CAUTION Unintentionally rotating drive!



Injuries to hands.
→ Verify that the rotation is displayed.



WARNING Risk of injuries due to retracting or entrapment!



Risk of injury.
A risk of entanglement exists on the movable parts of the unit.
→ Wear suitable protective clothing for activities on the rotary evaporator with goggles and gloves.



In order to always guarantee the same immersion depth of the evaporator flask, we recommend locking the immersion depth.

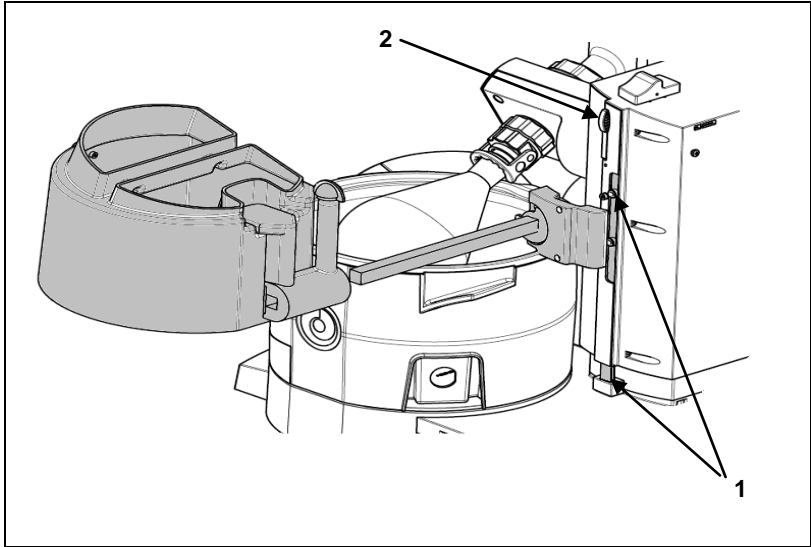

- ✓ Height stop (1) in the top position.
 - 1. Version **without a protective cover**:
 - Open the locking lever of the height stop (2) on the right of the lift column.
Manually push the height stop (1) down.
 - Move the lift down until the desired immersion depth is reached.
 - 2. Close the locking lever on the right of the lift column.
 - The immersion depth of the evaporator flask is locked.
 - 3. Version **with a protective cover**:
 - Move the lift down until the desired immersion depth is reached.
 - Hold the protective cover with your hand.
 - Open the locking lever on the right of the lift column.
 - 4. Feed the protective cover with your hand.
 - 5. Close the locking lever on the right of the lift column.
- The immersion depth of the evaporator flask is locked.

4.5.8 Release the evaporator flask from the vapor tube

WARNING

Glass breakage!



Serious injuries from shattering and breaking glass.



- Check glass devices for damages (stars, breaks, etc.).
- Only use perfect glass devices and replace all damaged glassware as soon as possible.
- Work carefully.



CAUTION

Unintentionally rotating drive!



Injuries to hands.

- Verify that the rotation is displayed.



WARNING

Risk of injuries due to retracting or entrapment!



Risk of injury.

A risk of entanglement exists on the movable parts of the unit.

- Wear suitable protective clothing for activities on the rotary evaporator with goggles and gloves.



WARNING

Hot media!



Burns.

- Do not touch the interior and the upper edge of the heating bath, the evaporator flask and the heating bath liquid.

- Wear suitable heat protection gloves when changing the evaporator flask.



1. Switch off the rotation.
2. Move the evaporator flask up from the bath (see chapter 4.4.6).
3. Let the evaporator flask cool (Figure 4-13 (1)).
4. Release the vapor tube coupling clamp flask ejector nut.

WARNING

Glass breakage!



Serious injuries from shattering and breaking glass.



- Check glass devices for damages (stars, breaks, etc.).
- Work carefully.



5. Release the flask from the vapor tube (Figure 4-6 (7)) by turning the vapor tube coupling clamp flask ejector nut counter-clockwise by supporting the flask.
6. Hold the evaporator flask and release the flask clamp.
7. Carefully remove the flask.

4.5.9 Insert the inlet tube

Insert the inlet tube

The inlet tube consists of:

- Stopcock (Stopper)
- PTFE tube
- Drain-off plate

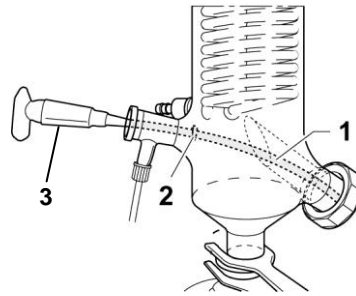

Figure 4–15: Insert the inlet tube

- | | |
|-------------|-------------------|
| 1 PTFE tube | 2 Drain-off plate |
| 3 Stopcock | |

1. Shorten the PTFE tube (1) to the desired length.
2. Grease the stopcock (3) (optional) for ideal vacuum.
3. Position the drain-off plate (2) so that the condensed liquid cannot return to the evaporator flask via the PTFE tube (1).
4. Insert the inlet tube

4.5.10 Assemble the inlet tube

Assemble the inlet tube

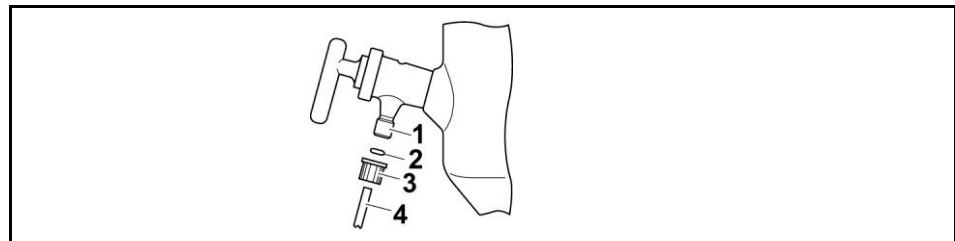

Figure4– 16: Assemble the inlet tube

- | | |
|--------------------------|--------------|
| 1 Inlet valve connection | 3 Cap |
| 2 Seal | 4 Inlet tube |

1. Guide the inlet tube (4) through the cap (3) and seal (2) assembled on the inlet valve connection (1).
2. Turn the cap (3) to the right on the inlet valve connection (1).

The inlet tube (4) is assembled on the inlet valve connection (1).

4.5.11 Assemble the collecting flask

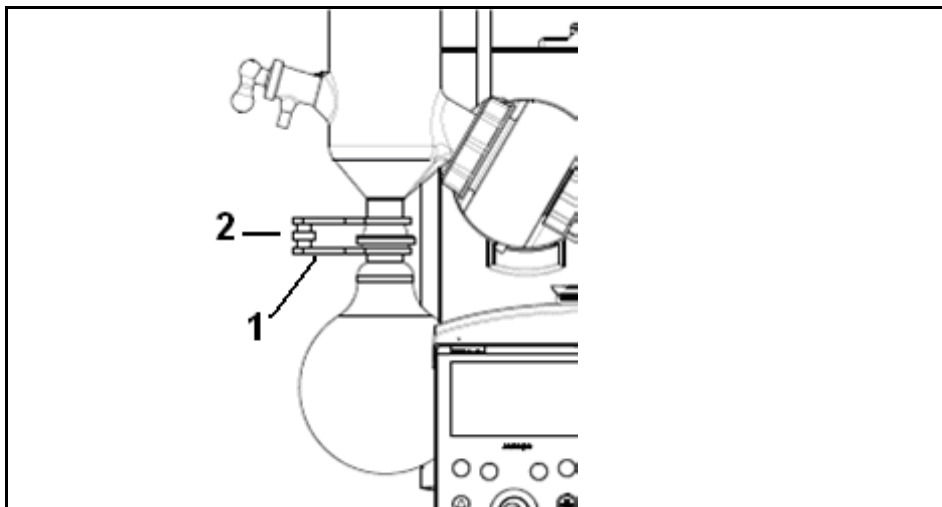

1. Hold the receiving flask with the ball-socket clamp KS 35 (1) to the condenser.
2. Secure with a knurled head screw (2).

The socket joint of the receiving flask is attached to the ball joint of the condenser via pinch clamp KS 35.

4.5.12 Connect the cooling medium (except G5)

- Use a suitable tube with an inner diameter of 7-8 mm (i.e. hose set (see accessories 11.2))

Connect the cooling medium

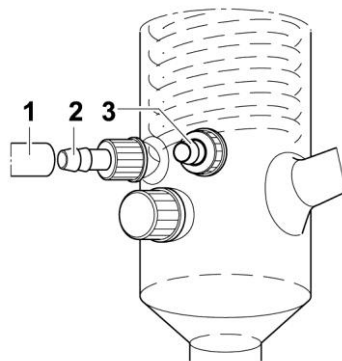

Figure 4-17: Connect the coolant

- | | |
|------------------------------------|--------------------------------|
| 1 Tube (coolant inlet) | 3 Return (GL hose barb) |
| 2 Connectors (GL hose barb) | |

1. Push the tube (coolant supply) (1) onto the hose barb of the inlet connector. Proceed accordingly with the return hose barb (3) of the coolant.
2. Secure with hose clamps.

Feed and return of the coolant are connected by screwing caps onto glass threads.

4.5.13 Connect the vacuum

Woulff flask with vacuum valve

The Woulff flask is connected to the vacuum valve (except in the Hei-VAP Precision with Rotavac vario control or with Rotavac vario tec).



WARNING Imploding glass devices!

Serious injuries from shattering glass.



- ➔ Check glass devices for damages (stars, breaks, etc.).
- ➔ Only use perfect glass devices and replace all damaged glassware as soon as possible.

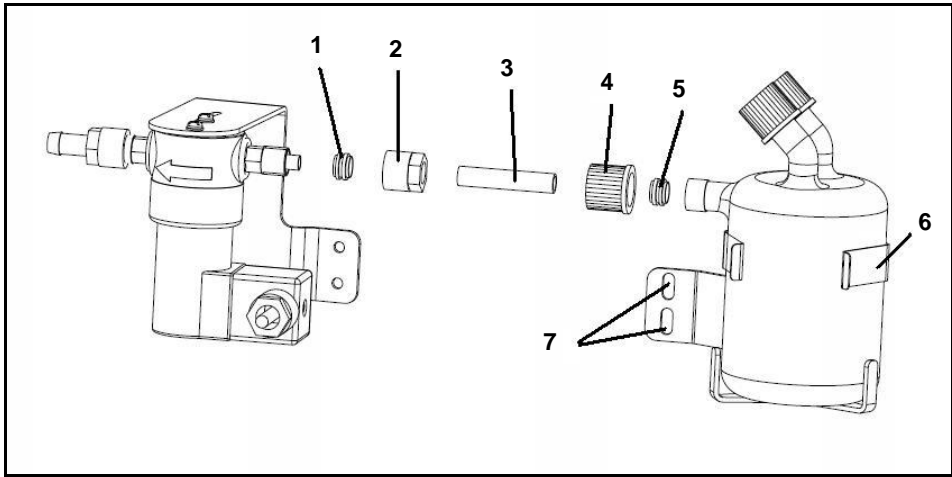
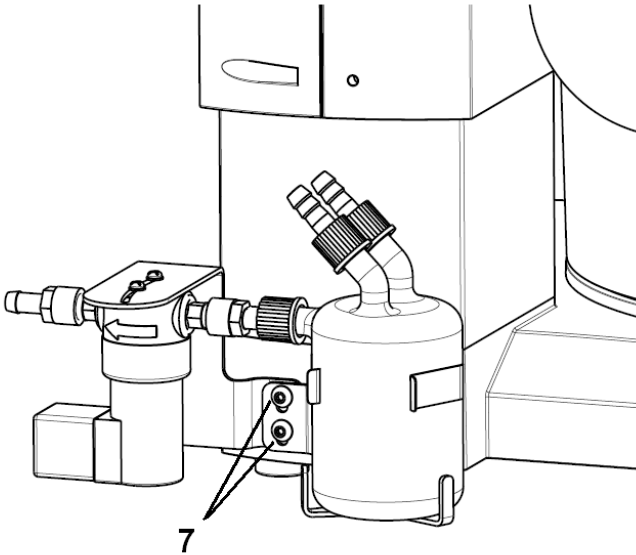

Figure 4-18: Connect the Woulff flask with vacuum valve

- | | | | |
|---|------------------------------|---|------------------------|
| 1 | Ferrule for the vacuum valve | 5 | Ferrule for the bottle |
| 2 | Cap nut | 6 | Mounting brackets |
| 3 | PTFE tube section | 7 | Screws |
| 4 | Threaded fitting cap | | |



1. Unscrew the threaded fitting (4) from the Woulff bottle, remove the hose clamp ring (5).
2. Place the enclosed PTFE tube section (3) in the cap nut (2) and tighten the cap nut (2).
3. Push the threaded connection (4) on the PTFE tube section (3), also push on the ferrule compression fitting (5).
4. Connect the Woulff bottle with the ferrule compression fitting (1).
5. The vacuum valve and Woulff bottle are connected.
6. Attach the connected Woulff bottle and the vacuum valve with the mounting brackets (6) and two screws (7) to the base unit.

- ✓ Suitable vacuum source is available.
- ✓ Suitable vacuum tube (7-8 mm) is available.

**Connection
Vacuum to the
glassware set**

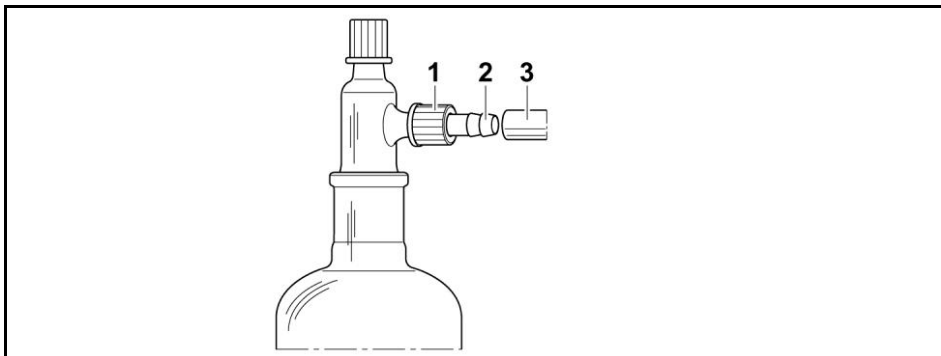

Figure 4–19: Vacuum connection

- | | |
|----------------------------|---------------|
| 1 Threaded fitting cap | 3 Vacuum tube |
| 2 Connector (GL hose barb) | |

1. Connect the vacuum hose (3) to the hose barb connector (2) to the threaded fitting cap (1).

Hose connection of individual vacuum systems, refer to the following pages.

Vacuum connection

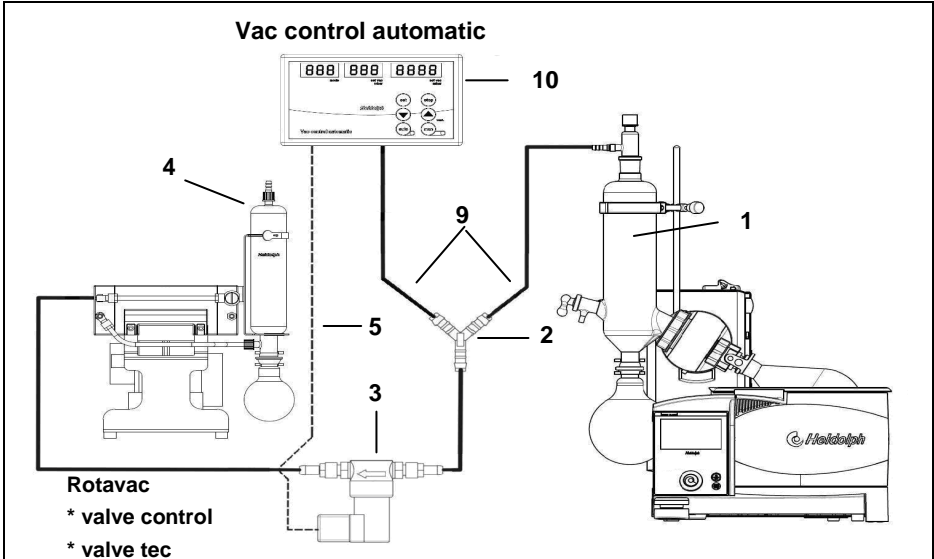

Figure 4-20: Hei-VAP Advantage with Rotavac valve control and Vac control automatic

- | | | | |
|---|------------------------------|----|-----------------------|
| 1 | Condenser | 8 | |
| 2 | Y-piece | 9 | Vacuum tube |
| 3 | Vacuum valve | 10 | Vac control automatic |
| 4 | Condensate cooler (optional) | 11 | |
| 5 | Vacuum valve cable | 12 | |
| 6 | | 13 | |
| 7 | | | |

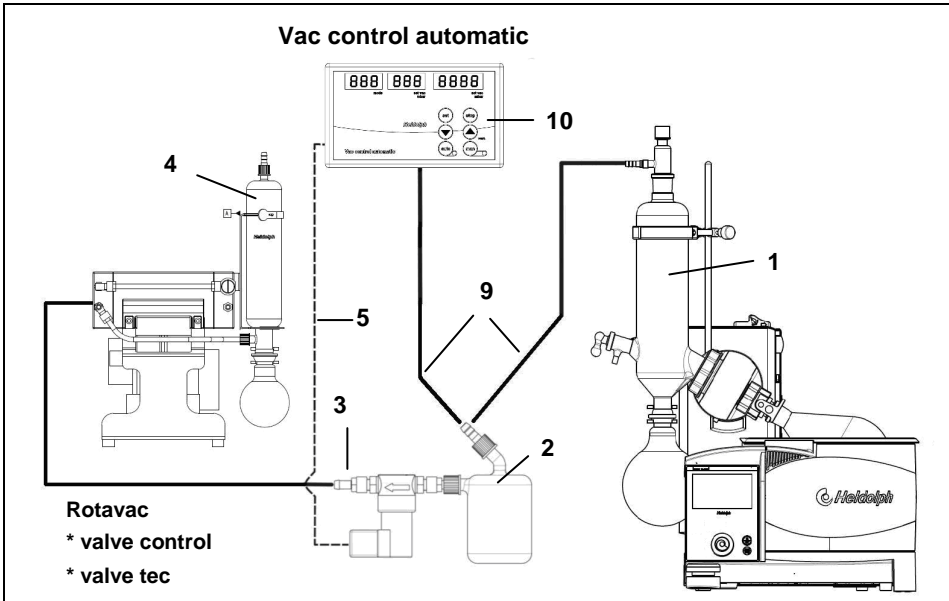

Figure 4-21: Hei-VAP Advantage with Rotavac valve control and Vac control automatic and with Woufff bottle

- | | | | |
|---|------------------------------|----|-----------------------|
| 1 | Condenser | 8 | |
| 2 | Woufff bottle | 9 | Vacuum tube |
| 3 | Vacuum valve | 10 | Vac control automatic |
| 4 | Condensate cooler (optional) | 11 | |
| 5 | Vacuum valve cable | 12 | |
| 6 | | 13 | |
| 7 | | | |

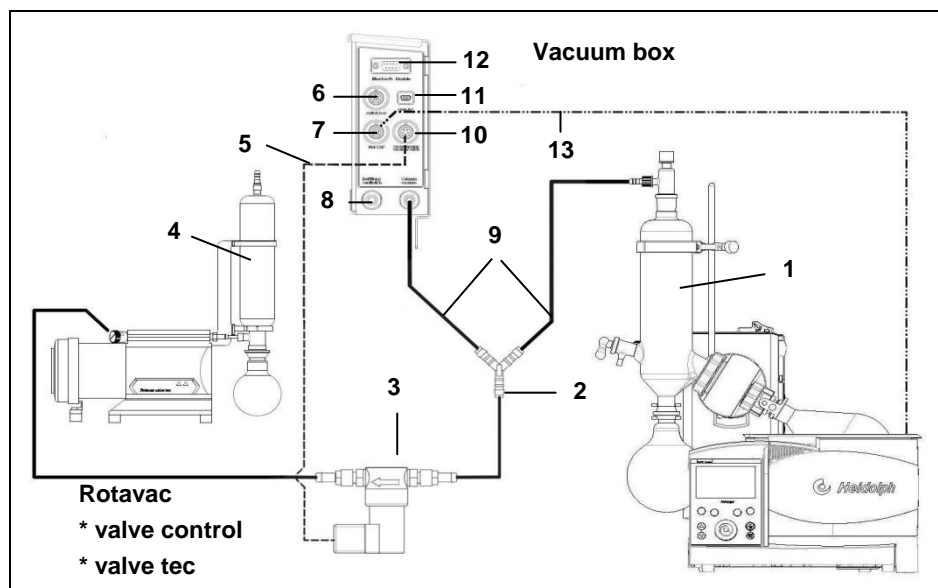

Figure 4-22: Hei-VAP Precision with Rotavac valve control and vacuum box

- | | | | |
|---|------------------------------|----|-------------------------------|
| 1 | Condenser | 8 | Ventilation / inert gas |
| 2 | Y-piece | 9 | Vacuum tube |
| 3 | Vacuum valve | 10 | Vacuum valve cable connection |
| 4 | Condensate cooler (optional) | 11 | USB PC connection |
| 5 | Vacuum valve cable | 12 | Bluetooth module |
| 6 | Switch box connection | 13 | Data cable |
| 7 | Hei-VAP connection | | |

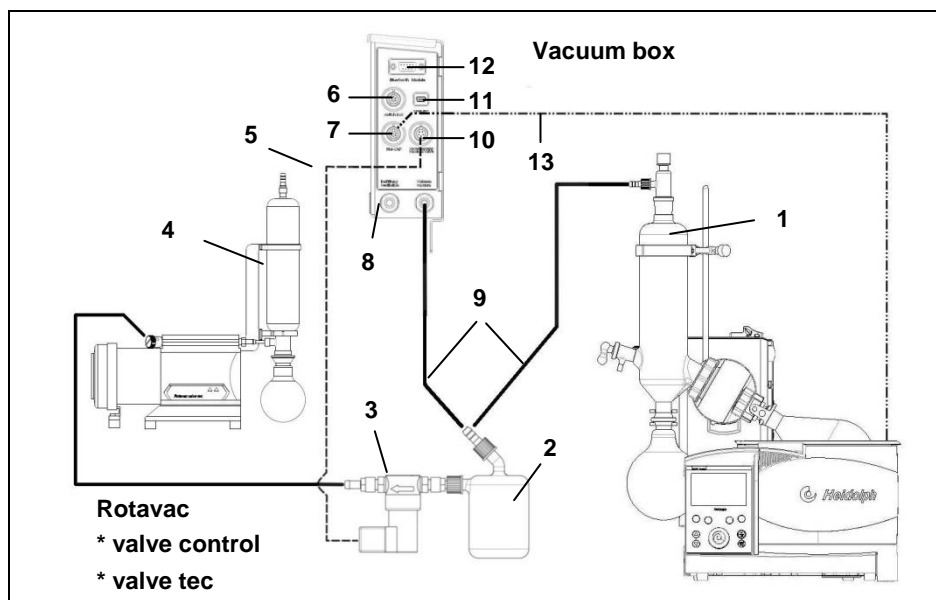

Figure 4-23: Hei-VAP Precision with Rotavac valve control and vacuum box and with Wouff bottle

- | | | | |
|---|------------------------------|----|-------------------------------|
| 1 | Condenser | 8 | Ventilation / inert gas |
| 2 | Wouff bottle | 9 | Vacuum tube |
| 3 | Vacuum valve | 10 | Vacuum valve cable connection |
| 4 | Condensate cooler (optional) | 11 | USB PC connection |
| 5 | Vacuum valve cable | 12 | Bluetooth module |
| 6 | Switch box connection | 13 | Data cable |
| 7 | Hei-VAP connection | | |

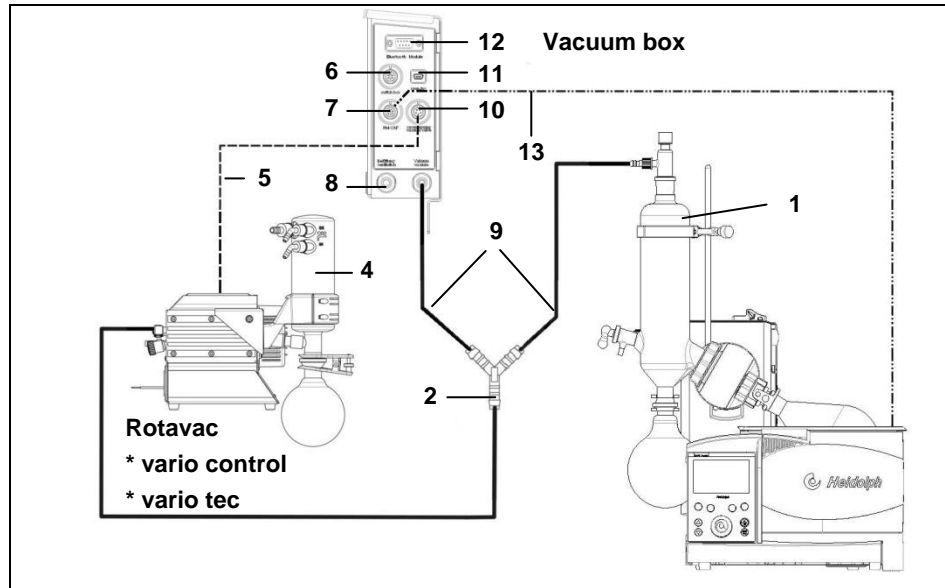

Figure 4-24: Hei-VAP Precision with Rotavac vario tec and vacuum box

- | | | | |
|---|---|----|-------------------------|
| 1 | Condenser | 7 | Hei-VAP connection |
| 2 | Y-piece | 8 | Ventilation / inert gas |
| 4 | Emission condensate cooler (optional) | 9 | Vacuum tube |
| 5 | Control cable Rotavac vario control / Rotavac vario tec | 10 | Vacuum pump connection |
| 6 | Switch box connection | 11 | USB PC connection |
| | | 12 | Bluetooth module |
| | | 13 | Data cable |

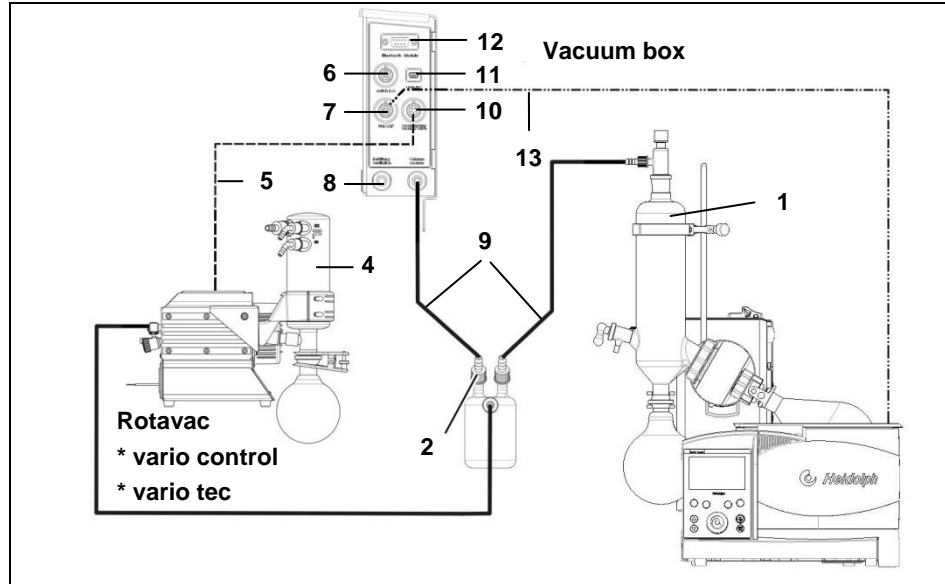

Figure 4-25: Hei-VAP Precision with Rotavac vario tec and vacuum box with Woulff bottle

- | | | | |
|---|---|----|-------------------------|
| 1 | Condenser | 7 | Hei-VAP connection |
| 2 | Woulff bottle | 8 | Ventilation / inert gas |
| 4 | Emission condensate cooler (optional) | 9 | Vacuum tube |
| 5 | Control cable Rotavac vario control / Rotavac vario tec | 10 | Vacuum pump connection |
| 6 | Switch box connection | 11 | USB PC connection |
| | | 12 | Bluetooth module |
| | | 13 | Data cable |

4.6 Feed the distilled material

Additional distillation material can be supplied during the distillation under vacuum via the inlet tube and the inlet pipe.

Inlet tube

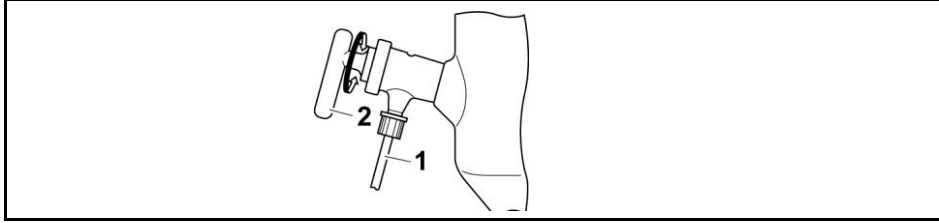

Figure 4-26: Inlet tube

- 1 Inlet tube 2 Stopcock

1. Place the inlet tube (1) in the additional distillation material.
2. Turn the stopcock (2) parallel to the inlet tube (1).

The additional distillation material is suctioned into the evaporation flask while system is under vacuum.

4.7 Ventilate manually

The system can be ventilated with the valve stopcock (Figure 4-26 (2)) of the inlet pipe.

- ➔ Slowly turn the stopcock (Figure 4-26 (2)) of the inlet tube upward.

The system will be ventilated.

4.8 Assemble / connect accessories

Protective hood

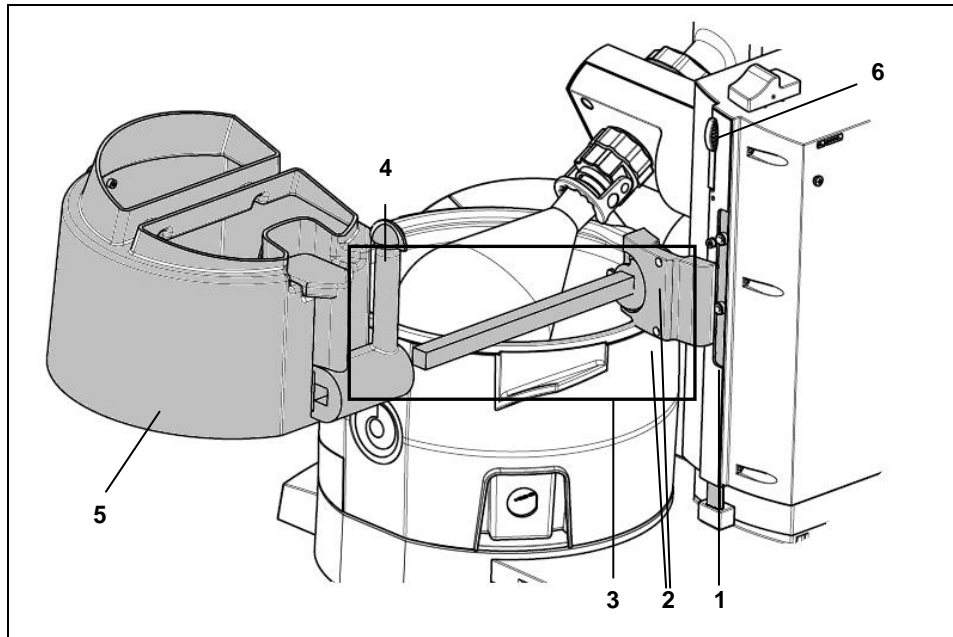

Figure 4-27: Assemble the protective cover

- | | | | |
|---|---------------|---|------------------|
| 1 | Height stop | 4 | Lock screw |
| 2 | Allen screws | 5 | Protective hood |
| 3 | Support cover | 6 | Height stop lock |

1. Screw the support cover (3) to the height stop (1) by using the two enclosed Allen screws (2).
2. Release the clamping screw (4) and align the cover (5) over the heating bath by shifting horizontally.
3. Tighten the clamping screw.

The cover is assembled. The cover can be opened by the handle.

Protective shield

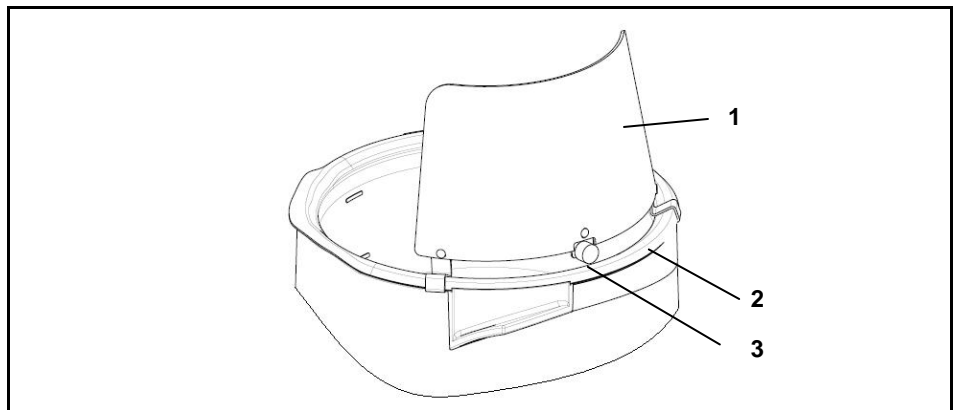

Figure 4-28: Assemble the protective shield

- | | | | |
|---|-------------------|---|-----------------|
| 1 | Protective shield | 3 | Eccentric screw |
| 2 | Heating bath | | |

1. Move the lift upward.
2. Attach the protective shield (1) on the edge of the heating bath (2) and position so that the (possibly available) cover can be easily opened.
3. Turn the eccentric screw (3) by 180° and use it to attach the protective shield on the heating bath.



When using the cover and the protective shield, take care that the two parts do not jam.

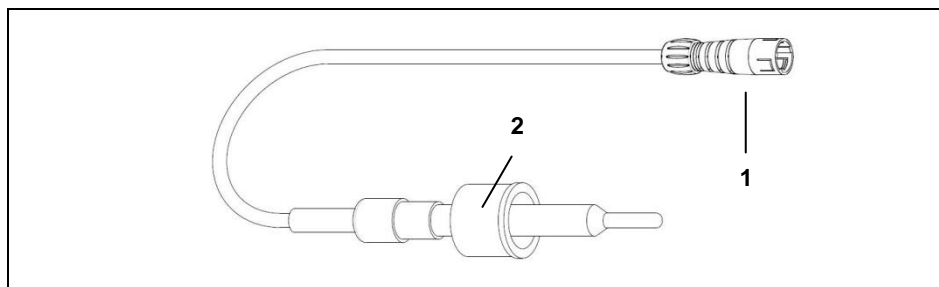

Vapor temperature sensor (Hei-VAP Advantage, Hei-VAP Precision)

Figure 4–29: Vapor temperature sensor

- | | | | |
|---|------|---|------|
| 1 | Plug | 2 | Seal |
|---|------|---|------|



The vapor temperature sensor cannot be used when using the temperature sensor Auto_{accurate} sensor.

1. Unscrew the threaded fitting on the condenser.
2. Insert the vapor temperature sensor into the condenser so that the white PTFE side of the seal (2) points to the glass thread.
3. Screw the vapor temperature sensor together with the threaded fitting.
4. Connect the plug (1) in the socket on the tower to the left of the unit (see chapter 5).

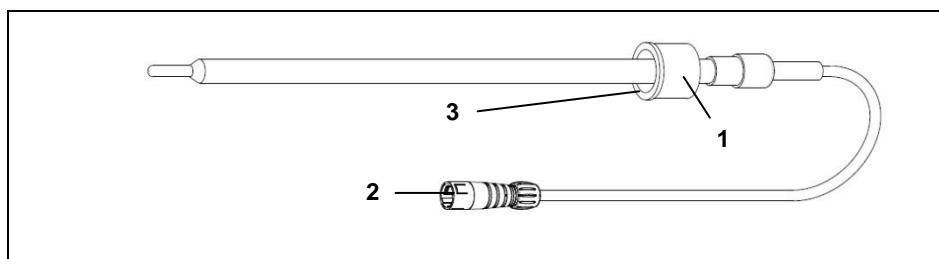

Temperature sensor Auto_{accurate} sensor

Figure 4–30: Temperature sensor Auto_{accurate} sensor

- | | | | |
|---|----------------------|---|-------------------------------|
| 1 | Threaded fitting cap | 3 | PTFE side of the sealing tube |
| 2 | Plug | | |

Only in conjunction with glassware sets G3 and G6.



Set the depth at which the temperature sensor Auto_{accurate} sensor projects into the condenser so that the lower edge of the sensor is located at 2/3 of the condenser's height.

1. Unscrew the threaded fitting on the vacuum port.
2. Insert the Auto_{accurate} sensor into the vacuum port so that the white PTFE side (3) of the seal points to the glass thread.
3. The depth of the Auto_{accurate} sensor is set on the condenser by adjusting the Auto_{accurate} sensor.
4. Screw together the Auto_{accurate} sensor with the threaded fitting (1).
5. Connect the plug (2) in the socket on the tower to the left of the unit (see chapter 5).

Control panel

4.9 Operating the control panel

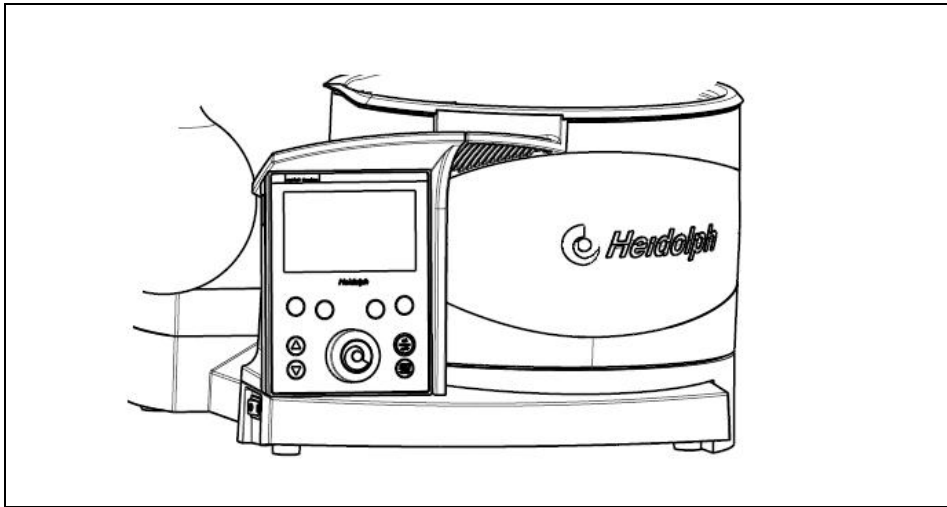
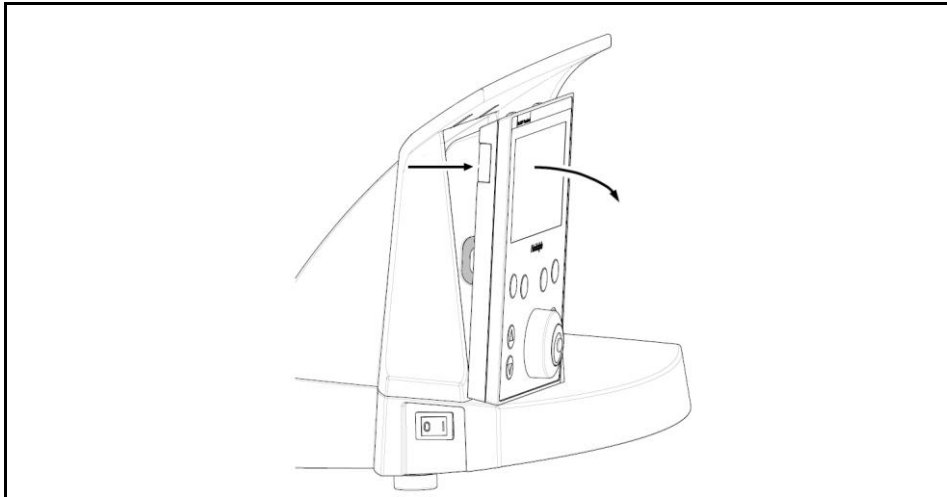

Figure 4–31: Control panel (for Hei-VAP Precision)



The control panel can be removed from the base unit.
The 1.3 m connecting cable between the control panel and the base unit can be adjusted to the optimal length by a cable run and reel.
The control panel can therefore be placed on a shelf and offers a slight inclination for a view from above.
The control panel can be attached to a wall by pre-fabricated holes or by an enclosed Velcro-connection.

Remove the control panel



1. Grasp the control panel on the left and pull it forward from the base unit.
Avoid pressure on the LCD screen.

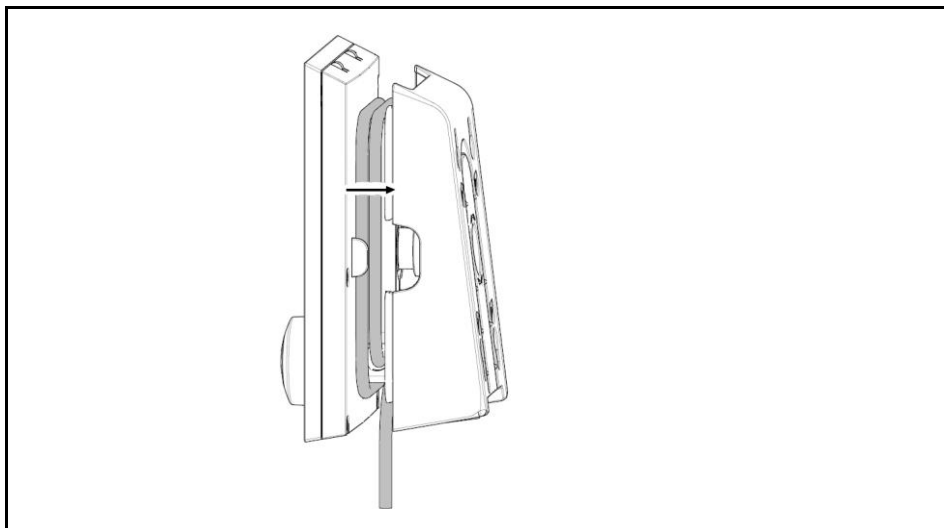

2. The cable reel is surrounded by a shell.
3. Pull the control panel apart, so that the cable reel can be seen.
The cable reel is surrounded by a shell.

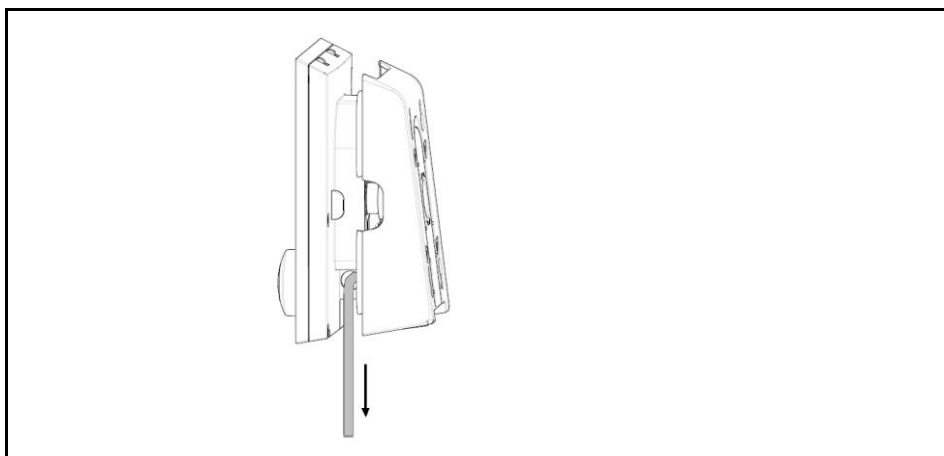

4. Reel in the cable to the desired length by wrapping the cable around the reel.
5. Press the shell to the control panel.

1. Pull the control panel apart, so that the cable reel can be seen.

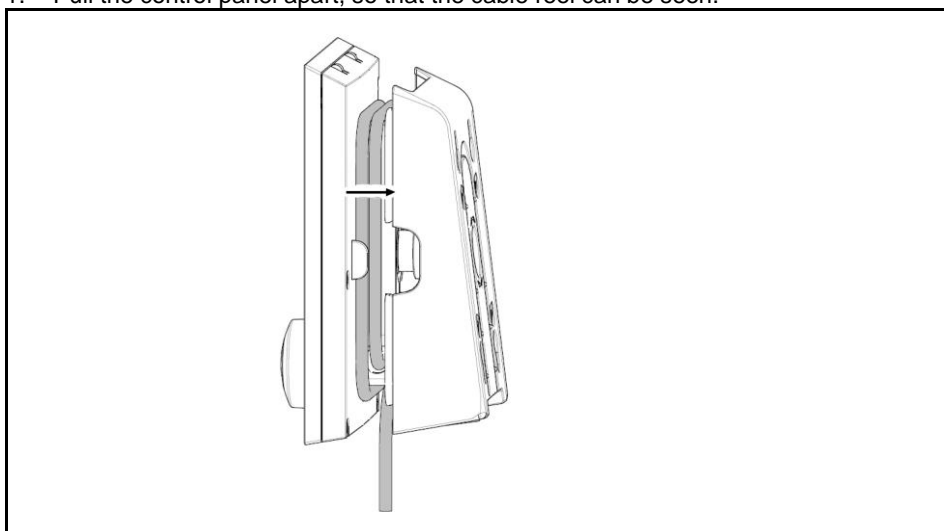

2. Reel in the cable to the desired length by wrapping the cable around the reel.
3. Press the shell to the control panel.

Control panel. Operation

The shell can be turned by 180° as desired, in order to adjust the surface and view to the control panel.

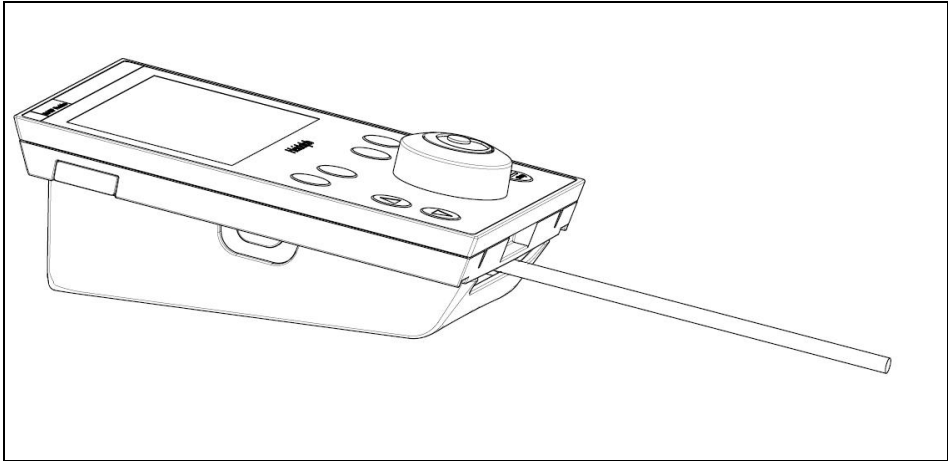
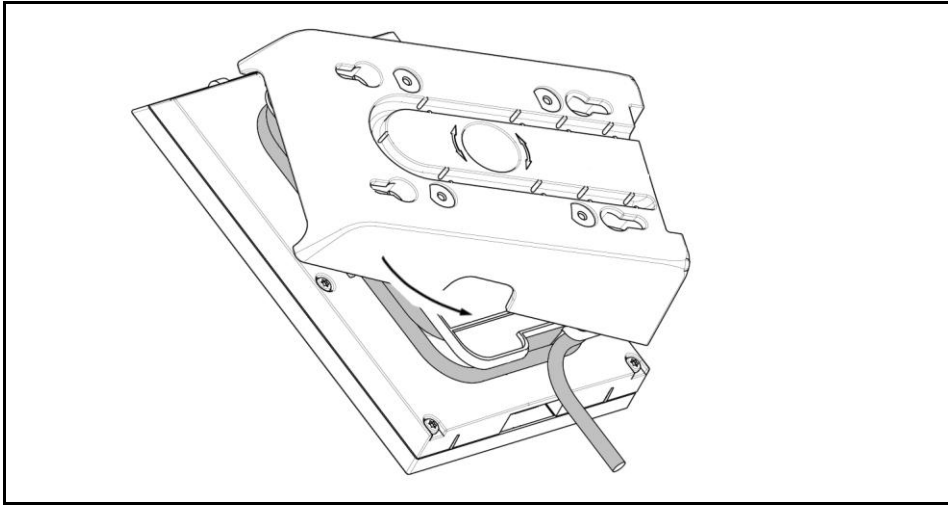

4. Place the control panel on the prefabricated guide rails that snap in and attach on the wall or deposit it on a stable surface.

Attaching the control panel to a fixture

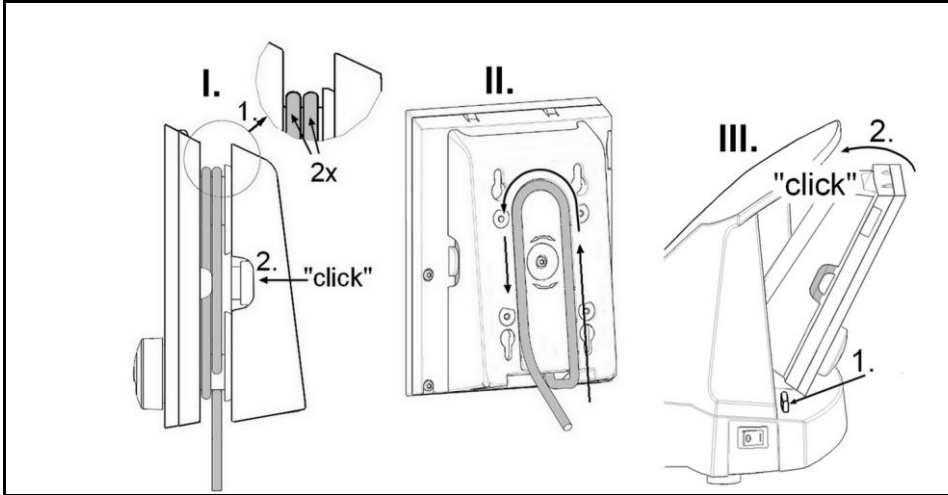

1. Attach the control panel back to the basic device.

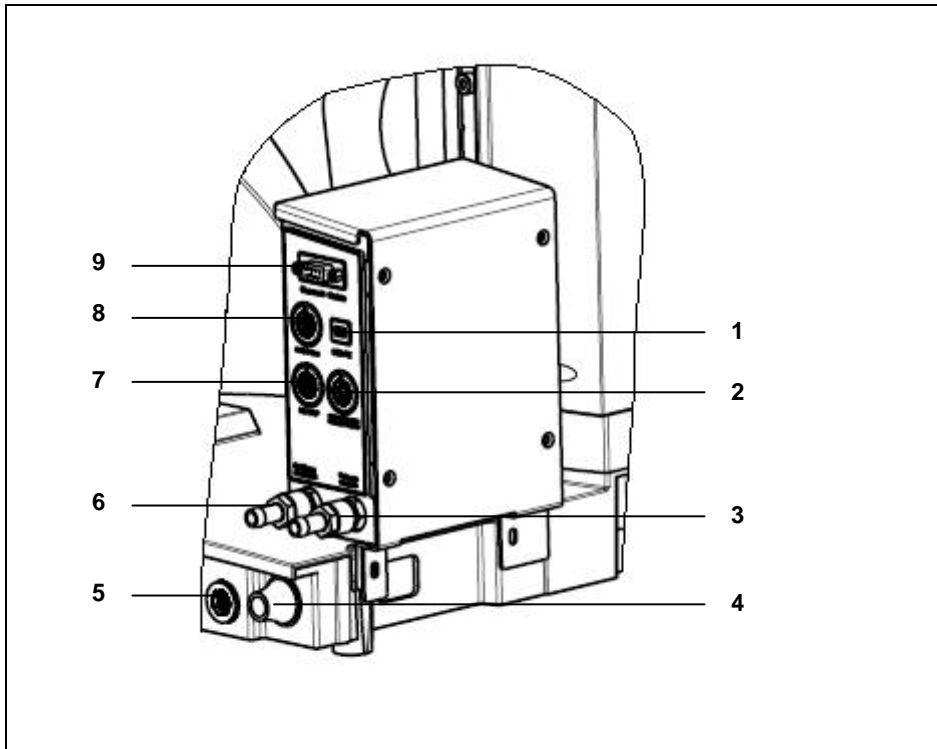

*Hei-VAP Precision
with vacuum box*

Figure 4–32: Vacuum box (for Hei-VAP Precision)

- 1 USB PC connection
- 2 Vacuum pump/Vacuum valve connection
- 3 Suction side of vacuum
- 4 Connecting line outlet to the heating bath
- 5 Vacuum box connection
- 6 Ventilation / inert gas
- 7 Hei-VAP connection
- 8 Switch box connection
- 9 Bluetooth module

1. Place the vacuum box on the guiderails behind the heating bath. The vacuum box brackets must be located above the holes.
2. Place the enclosed screws (2 pieces) in the holes with thread through the bracket of the vacuum box.
3. Tighten the fastening screw.
4. Insert the necessary or applicable connections (2, 3, 4, 5, 7, 8) into the Vacuum box.

5 Switching on the base unit

- 1. Switch on the base unit by pressing the toggle switch of the power switch.
- 2. The power switch of the base unit must be in the "1" position.



Figure 5-1: Base unit

- 1 Power switch
- 2 Temperature sensor connector

6 Operation of the Hei-VAP Value

The basic steps of operating the rotary evaporator Hei-VAP Value will be explained in this chapter.

6.1 Set the rotation speed

CAUTION



Unintentionally rotating drive!

Injuries to hands.

→ Verify that the rotation is displayed.



WARNING



Risk of injuries due to retracting or entrapment!

Risk of injury.

A risk of entanglement exists on the movable parts of the unit.

→ Wear suitable protective clothing for activities on the rotary evaporator with goggles and gloves.



- ✓ The control dial for rotation is turned to the counterclockwise or left position to ensure it is turned off.
- ✓ The unit is switched on.



The Distillation rate (dT) can be increased by increasing the speed of rotation.



Control panel

Figure 6–1: Control panel Hei-VAP Value

- 1 Heater indicator light
 - 2 Heating bath on/off
 - 3 Control knob for the rated heating bath temperature
 - 4 Control knob rotation
 - 5 Unit on indicator light
1. Switch on the base unit by pressing the toggle switch of the power switch. The power switch of the base unit must be in the "1" position. The unit on indicator light (5) is illuminated.
 2. Set the control knob rotation (4) to the desired speed.

6.2 Setting the heating bath temperature

- ✓ The control dial for the heating bath is turned to the counterclockwise or left position to ensure it is turned off.
- ✓ The heating bath is filled with a heat transfer liquid.
- ✓ The rotary evaporator is now operational and switched on at the power switch.



WARNING Hot surfaces during the operation of the heating bath!



Burns.

➔ Do not touch the interior and the upper edge of the heating bath, the evaporator flask and the heating bath liquid.



➔ Wear suitable heat protection gloves when changing the evaporator flask.



CAUTION Overheated heating bath!



Property damage and visual changes of the heating bath.

➔ Never operate the heating bath without liquid.



The heating bath has a dry run protection. This must be reset manually after being triggered (see Errors and Troubleshooting).



In order to achieve a high Distillation rate (dT), the temperature difference between the heating bath and the steam temperature must equal at least 20 K.

General: Doubling the temperature difference results in doubling the Distillation rate (dT).



For rated temperatures above 100 °C, only suitable oil or polyethylene glycol (order No.: 515-31000-00; 5L; max. temp.: 240 °C) may be used as heat transfer medium (observe safety data sheets, see chapter 4.4.2).

Heating bath

1. Switch on the heating bath by pressing the heating bath (Figure 6–1 (2) pushbutton on the control panel.
2. Set the required temperature with the heating bath (Figure 6–1 (3) control knob according to scale on the panel.

The control light of the heating bath (Figure 6–1 (1) shows that the heating bath is in the heating phase. It must be illuminated in green to show active heating of bath.

6.3 Error messages

The error messages in this unit's flashing codes are only displayed in the event of a malfunction. The flashing codes and their troubleshooting are explained in chapter 8, "Errors and Troubleshooting".

7 Operation of the Hei-VAP Advantage

The basic steps of operating the rotary evaporator Hei-VAP Advantage will be explained in this chapter.

The parameters for the distillation are set and monitored via the digital control panel.

The set parameters are stored in the operating panel. The last used parameters will appear after a restart or an extended break.

The starting screen is always the actual value display. The current actual values are displayed in large numbers.

Turning the **Hei-GUIDE** knob will allow you to change between individual entries. The particular selected entry is thereby illustrated and highlighted in a selection window. The selection window shifts when turning the Hei-GUIDE clockwise ("heating bath medium" -> "bath temp (heating bath)" -> "rotation (rotation)" -> "timer" (timer)).

The selected entry will be called up or engaged when pressing the **Hei-GUIDE**. The desired value can be set when turning the **Hei-GUIDE**.

Several functions are controlled by the **Hei-GUIDE** and allows for toggling between the different parameters.

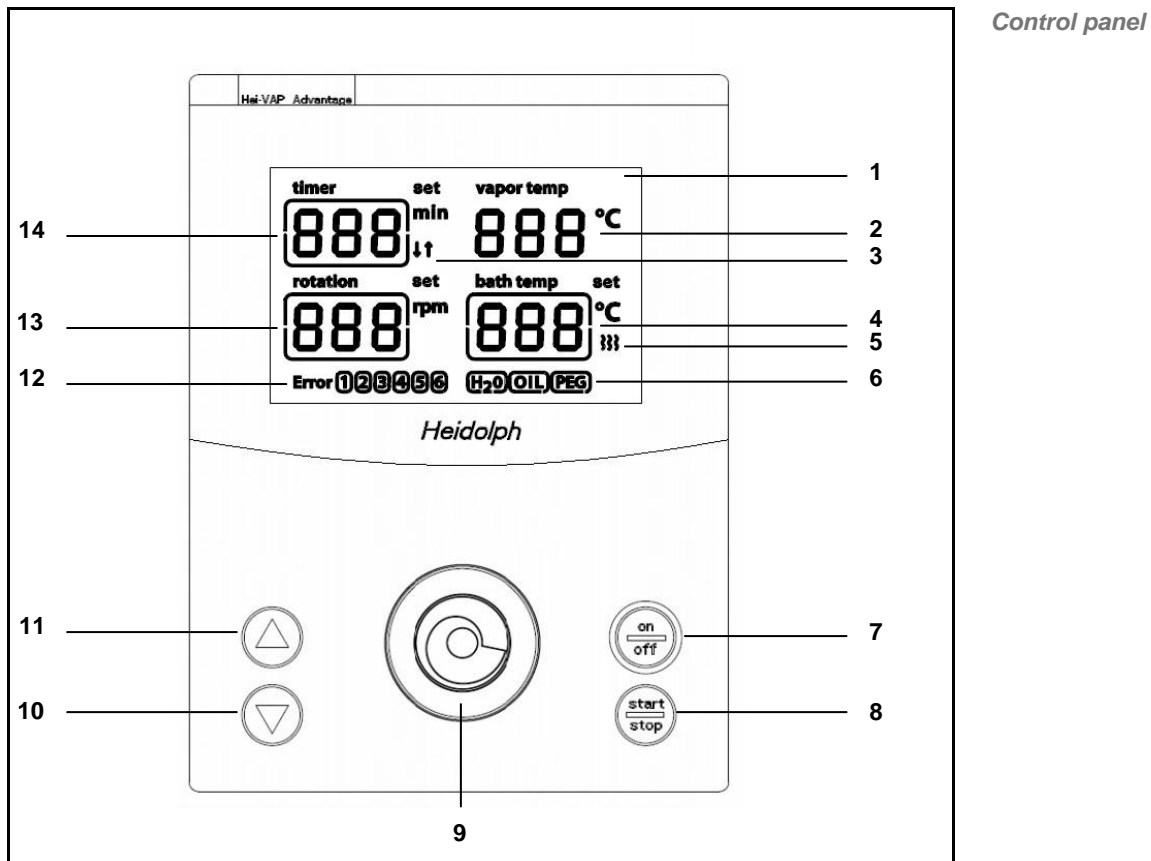

Figure 7–1: Control panel Hei-VAP Advantage (with motor lift)

- | | | | |
|---|-------------------------------|----|----------------------|
| 1 | Display | 8 | Rotation start/stop |
| 2 | Boiling temperature [°C] | 9 | Hei-GUIDE |
| 3 | Timer icon | 10 | Lift down |
| 4 | Heating bath temperature [°C] | 11 | Lift up |
| 5 | Heating icon | 12 | Error code |
| 6 | Heating bath medium | 13 | Rotation speed [rpm] |
| 7 | Heating bath on/off | 14 | Timer [min] |

7.1 Setting the heating bath temperature

- ✓ The heating bath is filled with heat transfer liquid.



WARNING

Hot surfaces during the operation of the heating bath!



Burns.

→ Do not touch the interior and the upper edge of the heating bath, the evaporator flask and the heating bath liquid.



→ Wear suitable heat protection gloves when changing the evaporator flask.



CAUTION

Overheated heating bath!



Property damage and visual changes of the heating bath.

→ Never operate the heating bath without liquid.



The heating bath has a dry run protection. This must be reset manually after being triggered (see Errors and Troubleshooting).



The unit has a power backup system. The heating bath is switched off when the power returns.

The unit maintains the last settings. The rated temperature of the heating bath is displayed when the power is on.

The remaining residual time is stored by the timer. The timer is triggered again after the power returns.



In order to achieve a high Distillation rate (dt), the temperature difference between the heating bath and the vapor temperature must equal at least 20 K.

General: Doubling the temperature difference results in doubling the Distillation rate (dT).



For rated temperatures above 100 °C, only suitable oil or polyethylene glycol (order No.: 515-31000-00; 5L; max. temp.: 240 °C) may be used as heat transfer medium (observe safety data sheets, see chapter 4.4.2).

Heating bath medium

7.1.1 Select heating bath medium

- Switch on the base unit by pressing the power switch (Figure 5–1 (1)).
The toggle switch of the base unit must be in the "1" position.
- Activate the heating bath medium (OIL or H₂O) (6) with the support of the selection window by using the rotary pushbutton **Hei-GUIDE** (9).
- The selection window flashes when pressing the rotary pushbutton **Hei-GUIDE** (9).
- Pressing the **Hei-GUIDE** (9) again takes over the selected heating bath liquid. The selection window jumps to "bath temp" and flashes.

The target temperature is displayed when switching the unit on again. The selection window is on the last selected medium. Confirming the medium and confirming the target temperature twice will take over the last settings.

The target value is set at 20 °C after a previous change of the heating bath medium from "OIL" to "H₂O", if a target value of more than 100 °C was set.

The last set medium will be taken over after 10 seconds of inactivity of the **Hei-GUIDE**. The window then jumps to "rotation" at rotation "off".

7.1.2 Setting the heating bath temperature

→ Select the heating bath medium via the control panel.

1. Activate the heating bath temperature display with the aid of the selection window by using the rotary pushbutton controller **Hei-GUIDE** (9).
2. The selection window flashes when pressing the rotary pushbutton controller **Hei-GUIDE** (9). The current target temperature will be displayed. This value can be changed.

Display values: 20 °C to +210 °C in single °C steps

3. Turn the rotary pushbutton controller **Hei-GUIDE** (9) to set the display value to the desired target temperature.

If the target temperature is exceeded past 100 °C, the selection window will be displayed and a frame around the **OIL** (6) display will flash.

Pressing the button again confirms that a suitable medium (OIL) is available in the heating bath.

The temperature display flashes and can be set to the desired temperature.

4. Pressing the **Hei-GUIDE** (9) again takes over the reset value and the selection window is permanently illuminated.

The actual temperature is displayed after confirmation.

The evaporator responds immediately, if the heating bath is switched on.

If the target temperature of more than 100 °C is changed to less than 100 °C, the display **OIL** (6) remains until the next activation.

The frame is faded out after 10 seconds of inactivity of the **Hei-GUIDE**.

5. Switch on the heating bath by pressing the pushbutton **heating bath on/off** (7).

The heating bath indicator light indicates that the heating bath is switched on. It must be illuminated in green.

The heating icon (5) next to the "bath temp" display is illuminated, if the heating bath is in the heating phase.

Heating bath temperature

7.2 Set the rotation speed

CAUTION



Unintentionally rotating drive!

Injuries to hands.

→ Verify that the rotation is displayed.



WARNING



Risk of injuries due to retracting or entrapment!

Risk of injury.

A risk of entanglement exists on the movable parts of the unit.

→ Wear suitable protective clothing for activities on the rotary evaporator with goggles and gloves.



- ✓ The unit is switched on.
- ✓ The rotary evaporator is operational and switched on at the power switch.



The rotation remains in the connecting solution between the control panel and the evaporator.



The Distillation rate (dT) can be increased by increasing the speed.
The set target value is automatically assumed after 10 s.

Rotation speed

1. Activate the rotation display with the aid of the selection window by using the rotary pushbutton controller **Hei-GUIDE** (9).
2. Pressing the rotary pushbutton **Hei-GUIDE** (9) makes it possible to change the value. The selection window flashes.
3. Turn the rotary pushbutton knob **Hei-GUIDE** (9) to set the display value to the desired target speed.

The evaporator responds immediately, if the rotation has been switched on via the **Rotation start** (8) pushbutton.

If timing has not been set, the time will be counted upward after pressing the **Rotation start** (8) pushbutton. An arrow "up" will be inserted under the min display.

4. Switch on the rotation by pressing the **Rotation start** (8) pushbutton. The speed display shows the actual value.



If the rotation has not started after 10 seconds of inactivity of the **Hei-GUIDE**, the frame jumps to the **Rotation** parameter, the target value and the frame will be displayed until the rotation is started by the rotation pushbutton "**start/stop**".

The selection window is activated by the rotation speed at rotation "off" and the target value of the rotation, the target value for "timer" (if selected) and the actual values for "bath temp" and "vapor temp" will be displayed.

A selection window will not be displayed at **rotation** "on", but only the current values.

7.3 Calculating the boiling temperature (Hei-VAP Advantage)

- ✓ The unit is switched off.
 - ✓ The vapor temperature sensor (optional) is connected to the temperature sensor socket (Figure 5-1 (2))
- ➔ Switch the unit on.

Boiling temperature

The vapor temperature appears on the screen of the rotary evaporator "vapor temp", if the vapor temperature sensor is connected.

7.4 Timing functions

7.4.1 Timer

The timer function stops the distillation after a set period.



A set timer is displayed by inserting an arrow "down" below the min. display.

If a timer is not set, the timer is always counted upward. The arrow "up" is inserted.

1. Activate the timing display with the aid of the selection window by using the rotary pushbutton controller **Hei-GUIDE** (9).
2. The selection window flashes when pressing the rotary pushbutton **Hei-GUIDE** (9). The value can therefore be adjusted. A time between 1 and 999 minutes can be selected by turning the Hei-GUIDE (9).
3. Turn the rotary pushbutton controller **Hei-GUIDE** (9) to set the display value to the desired timing value.
4. Pressing the **Hei-GUIDE** (9) again takes over the selected new value. The evaporator responds immediately and the time is counted backward.
5. An arrow "down" (3) will be inserted under the minute display.

Timer

The time is running backwards at the start of the rotation with the **Rotation start** (8) pushbutton. The distillation is interrupted after completing the set time.

- the timer display shows "000" with a flashing frame
- Motor lift version:
 - The rotation is switched off.
 - The lift is raised (only Hei-VAP Advantage, Hei-VAP Precision).
 - The heating bath is switched off.
- Hand lift version
 - The rotation changes to 20 rpm till manual intervention by the user.
 - The heating bath is switched off.



The screen is reset to value "---" when activating the Hei-GUIDE (turning or pressing), the frame flashes, and the value can be change or confirmed.

If value "---" is confirmed by pressing the Hei-GUIDE, the timer will count the run time upward after the start of the rotation. The up arrow will be illuminated. This value and the frame will flash when reaching the maximum value of "999". The process will continue.

The value is set at zero and the "timer" will again count upward when activating the Hei-GUIDE (turning or pressing), if the process has not been stopped.

7.5 Error messages

Error messages are only displayed in the event of an error. The error codes 1 to 6 and their troubleshooting are explained in chapter 8, "Errors and Troubleshooting".

7.6 Upgrading



An upgrade from the evaporator model Hei-VAP Advantage to evaporator model Hei-VAP Precision is possible by changing the control panel and adding a vacuum box.

8 Errors and Troubleshooting

8.1 General errors

Error / message	Cause	Remedy
Unit cannot be switched on	Main plug not connected to the main power supply	→ Connect the main plug with the power supply
	Fuses defective or blown fuse	→ Replace fuses (see chapter 9.2)
No heating function	Master switch is deactivated	→ Activate main switch
	Fuses defective or blown fuse	→ Replace fuses (see chapter 9.2)
	Master switch is defective	→ Contact service
	The connecting cable of the heating bath is not connected.	→ Connect the connecting cable of the heating bath
	The heater of the heating bath is defective	→ Contact service
	The maximum temperature limiter responded	→ If the medium was in the heating bath: Let the heating bath cool and reset the maximum temperature limiter → If the medium was not in the heating bath: Contact service
Drive unit is not rotating	Master switch is defective	→ Contact service
	Speed controller is on the left stop (Hei-VAP value)	→ Turn the speed controller to the right
	Drive unit is defective	→ Contact service
	Fuses defective or blown fuse	→ Replace fuses (see chapter 9.2)
Motor lift is not functioning	Master switch is deactivated	→ Activate main switch
	Master switch is defective	→ Contact service
	Fuses defective or blown fuse	→ Replace fuses (see chapter 9.2)
	Lift is at end stop	→ Activate other arrow key
	Mechanical system / motor is defective	→ Contact service
	Height stop is not set accurately	→ Perform height adjustment (see chapter 4.5.7)

Error / message	Cause	Remedy
No evacuation	Power switch Rotavac vario control or Rotavac vario tec is not activated. Vacuum valve is defective.	→ Activate the power switch
	Fuses defective or blown fuse	→ Replace fuses (see chapter 9.2)
Insufficient vacuum	System leaks	→ Check seals, tubing and connections → Check stopcocks, grease if necessary
	Vacuum pump is defective	→ Observe manufacturer's instructions of the vacuum pump
Unit suddenly switches off (Hei-VAP Precision and Hei-VAP Advantage)	Timer is programmed	→ Check and switch off the timer, if necessary (see chapter 7.4.1)
	Fuses defective or blown fuse	→ Replace fuses (see chapter 9.2)

Table 8-1: Troubleshooting table

8.2 Additional conditions

Additional conditions	Reaction
Vapor sensor is defective	– The actual value curve is displayed “---“ instead of the vapor temperature.
The vapor sensor is not connected	– The vapor temperature is not displayed in the actual value display
Heater can only be activated at >0 °C (observe acetone, dry ice)	

Table 8-2: Additional conditions

8.3 Hei-VAP Value

Error / message (flashing code)	Cause	Remedy
**	<ul style="list-style-type: none"> – No data received at all for 3 seconds → Cable connection between the control panel and the base unit was disconnected. An error occurred in the data bus. 	<ul style="list-style-type: none"> → Restore the cable connection between the control panel and the base unit. Switch the power switch off and on again. → Contact service
***	<ul style="list-style-type: none"> – Heater is defective, i.e. the overheating protection was triggered. 	<ul style="list-style-type: none"> → If the medium was in the heating bath: Let the heating bath cool and reset the maximum temperature limiter → If the medium was not in the heating bath: Contact service
	<ul style="list-style-type: none"> – HB safety temperature (+5 K) is exceeded 	<ul style="list-style-type: none"> → Contact service
	<ul style="list-style-type: none"> – Heating bath is completely evaporated. 	<ul style="list-style-type: none"> → Deactivate the unit → Check if the maximum temperature limiter has responded. If yes, reset (see chapter 9.1.1) → Fill in heat transfer fluid
	<ul style="list-style-type: none"> – Heating bath sensor variance > 10 K 	<ul style="list-style-type: none"> → Contact service
	<ul style="list-style-type: none"> – Sensor monitoring via hardware HB sensor broken or short circuited 	<ul style="list-style-type: none"> → Contact service
	<ul style="list-style-type: none"> – The temperature sensor for monitoring the heating bath control is broken or the temperature of the medium in the heating bath is > 217 °C. 	<ul style="list-style-type: none"> → Cool down the heating bath medium → Contact service
	<ul style="list-style-type: none"> – The temperature sensor for the heating bath control is short circuited or the temperature is below 0 °C 	<ul style="list-style-type: none"> → Contact service
****	<ul style="list-style-type: none"> – Potentiometer temp. is defective (value) 	<ul style="list-style-type: none"> → Contact service
	<ul style="list-style-type: none"> – Potentiometer speed is defective (value) 	<ul style="list-style-type: none"> → Contact service
*****	<ul style="list-style-type: none"> – Motor is not rotating: – Motor overload shutdown 	<ul style="list-style-type: none"> → Deactivate the unit → Stop drive unit for cooling down → Contact service

Table 8-3: Troubleshooting table - Hei-VAP Value

8.4 Hei-VAP Advantage

Error / message (error label)	Cause	Remedy
1	The transportation protection device is still activated. (only motor lift version)	→ Please raise the lift and briefly switch the unit off and then on again.
	<ul style="list-style-type: none"> – No data received at all for 3 seconds → Cable connection between the control panel and the base unit was disconnected. An error occurred in the data bus.	→ Restore the cable connection between the control panel and the base unit. Switch the power switch off and on again. → Contact service
3	<ul style="list-style-type: none"> – Heater is defective, i.e. the overheating protection was triggered. 	→ If the medium was in the heating bath: Let the heating bath cool and reset the maximum temperature limiter → If the medium was not in the heating bath: Contact service
	<ul style="list-style-type: none"> – Heating bath safety temperature (+5 K) is exceeded 	→ Contact service
	<ul style="list-style-type: none"> – Heating bath is completely evaporated. 	→ Deactivate the unit → Check if the maximum temperature limiter has responded. If yes, reset (see chapter 9.1.1) → Fill in heat transfer fluid
	<ul style="list-style-type: none"> – Heating bath sensor variance > 10 K 	→ Contact service
	<ul style="list-style-type: none"> – Sensor monitoring via hardware HB sensor broken or short circuited 	→ Contact service
	<ul style="list-style-type: none"> – The temperature sensor for monitoring the heating bath control is broken or the temperature of the medium in the heating bath is > 217 °C. 	→ Cool down the heating bath medium → Contact service
	<ul style="list-style-type: none"> – The temperature sensor for the heating bath control is short circuited or the temperature is below 0 °C 	→ Contact service
5	<ul style="list-style-type: none"> – Motor is not rotating: 	→ Deactivate the unit
	<ul style="list-style-type: none"> – Motor overload shutdown 	→ Stop drive unit for cooling down → Contact service

Table8-4: Troubleshooting table - Hei-VAP Advantage

The rotary evaporator is checked after "power on" in an initialization phase for connected components. The function scope of the rotary evaporator is based on the connected units.

Missing component	Description and response of the evaporator	Remedy
Temperature sensor T boiling	The temperature sensor for calculating the boiling temperature is not connected: <ul style="list-style-type: none"> - The vapor temperature is not displayed 	<ul style="list-style-type: none"> ➔ Connect component ➔ Reset via power off/on

Table 8-5: Missing components

9 Maintenance, cleaning, service

9.1 Maintenance

- Only use genuine parts approved by the manufacturer!

Maintenance

The vapor tube and PTFE 26 vacuum seal must be routinely serviced.

1. Remove and clean the vapor tube and the PTFE 26 vacuum seal (see chapter 4.5.2).
2. Check the PTFE 26 vacuum seal for damages and wear, replace if necessary.

9.1.1 Resetting the maximum temperature limiter

In the event that the temperature controller malfunctions and the heating bath temperature exceeds the maximum temperature of 250 °C, the maximum temperature limiter will switch off the heating bath.

Maximum temperature limiter

- ✓ The heating bath is cooled and disconnect from power-supply. Power-switch off.

WARNING

Hot surfaces!



Burns.

- Cool the heating bath.



WARNING

Verify that the basic device is only plugged to or unplugged from the heating bath if the main switch is switched off and/or the main power supply is disconnected.



1. Remove the heating bath liquid from the heating bath.

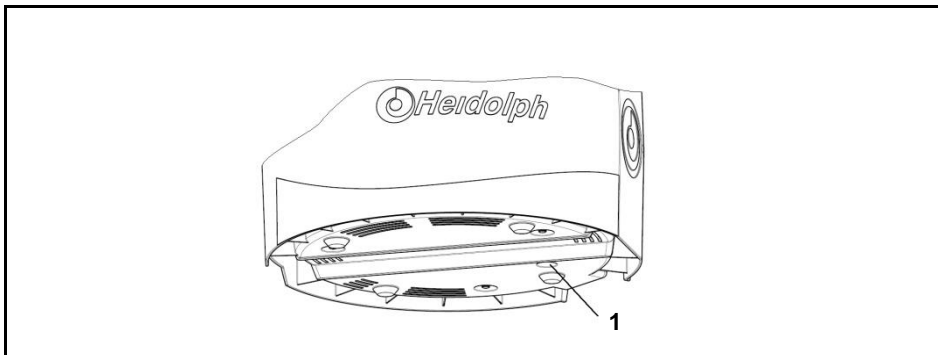

Maximum temperature limiter

Figure 9–1: Maximum temperature limiter

2. Press the maximum temperature limiter (1), possibly with a pointed object.

9.1.2 Evacuate the heating bath



WARNING



Verify that the basic device is only plugged to or unplugged from the heating bath if the main switch is switched off and/or the main power supply is disconnected.

Evacuating the heating bath

1. The heating bath is cooled and disconnect from power-supply. Power-switch off.
2. Take the heating bath from off the device.

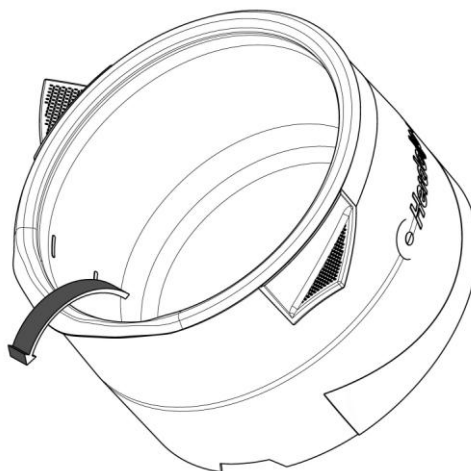

3. The edge of the heating bath is designed to easily evacuate the heating bath. Evacuate the heating bath.

9.1.3 Readjust the vacuum seal (glassware set G6)

Vacuum seal

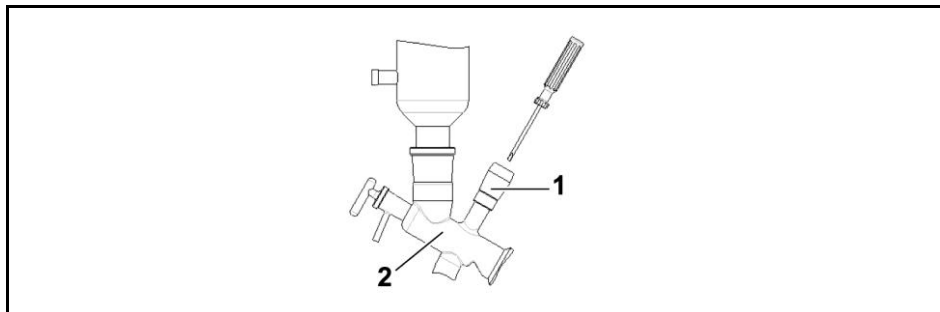

Figure 9-2: Readjust the vacuum seal - glassware set G6

- 1 Valve
- 2 Center piece G6

The seal in the valve (1) can be readjusted with a screwdriver.



WARNING

Glass breakage!



Cuts.



→ Work carefully; do not readjust the adjusting screw too much.



1. Screw the valve into the G6 center piece (2) up to the stop.
2. Turn the adjusting screw clockwise until a white ring can be seen at the shaft of the glass.

9.2 Replacing the fuses

The fuses are located on the bottom of the unit.

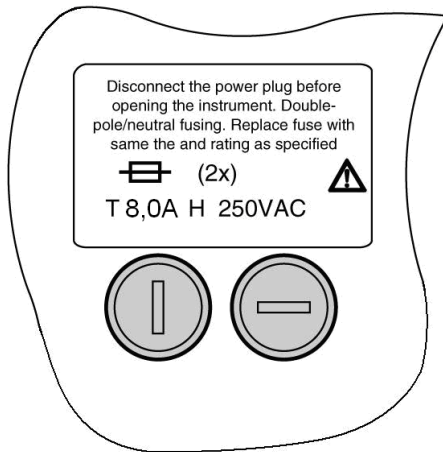

Fuse

Figure 9–3: Fuse on the bottom of the unit

CAUTION



The drive unit and the heating bath may be switched on accidentally!

Injuring and burning hands.

- Verify that the power switch for the base unit and the heating bath is switched off via the pushbutton.



WARNING



Risk of injuries due to retracting or entrapment!

Risk of injury.

A risk of entanglement exists on the movable parts of the unit.

- Wear suitable protective clothing for activities on the rotary evaporator with goggles and gloves.



1. Disconnect the unit from the power plug.
 2. Remove evaporating flask.
 3. Cool the heating bath liquid and remove the heating bath from the base unit by disconnecting the power plug.
 4. Carefully tilt the unit and pour out the bath media.
 5. Dry the bath and turn it over with the bottom facing upward.
 6. Remove the defective fuse by using a screwdriver.
 7. Insert a suitable new fuse and tighten with a screwdriver.
- The fuse has been replaced. The unit can be returned to active heating operation.

9.3 Cleaning



CAUTION

Damages due to corrosive cleaning agents!



Damages on the surface of the unit.



- ➔ Use only mild soap solutions. Never use chlorine bleach or cleaning agents that are chlorine based. Never use abrasives, ammonia, cleaning rags or cleaning agents with metal parts.

- ➔ Wipe the surfaces of the unit with a damp cloth (mild soap solution).

9.4 Service

Your unit is not working?

1. Please contact Heidolph Instruments or your authorized Heidolph Instruments dealer via telephone or email.

Addresses and telephone numbers

















In Germany,	Tel:	0800-HEIDOLPH or
Austria and Switzerland:		0800-4 3 4 3 6 5 7 4 (Free call)
		+49 (0) 91 22 99 20 69
	Fax:	+49 (0) 91 22 99 20 65
	E-mail:	sales@heidolph.de

2. After consulting with a Heidolph service employee:
 - Copy and complete a declaration of non-objection from these instructions, if necessary
 - Package the unit for shipping per the recommended methods of the service department and mail to the following including the declaration of non-objection:

Heidolph Instruments GmbH & Co. KG
Vertrieb Labortechnik
Walpersdorfer Str. 12
91126 Schwabach / Germany

10 Dismantling, storage, disposal

10.1 Disassembly

CAUTION	Unintentionally rotating drive!	
	Injuries to hands. → Verify that the rotation is displayed.	
WARNING	Risk of injuries due to retracting or entrapment!	
	Risk of injury. A risk of entanglement exists on the movable parts of the unit. → Wear suitable protective clothing for activities on the rotary evaporator with goggles and gloves.	
		
WARNING	Hot surfaces!	
	Scalding and burns. → Let the heating bath and glass devices cool.	
		
WARNING	Glass breakage!	
	Cuts. → Work carefully.	
		
		
→ Dismantle the glassware sets in reverse sequence of the assembly (see chapter 4.5).		
10.1.1 Remove the Woulff bottle		
WARNING	Glass breakage!	
	Cuts. → Work carefully.	
		
		
→ Remove the Woulff bottle in reverse sequence of the assembly (see chapter 4.5.13).		

Woulff bottle

10.1.2 Disconnecting the coolant / vacuum

Coolant / vacuum

1. Verify that the coolant and vacuum supply is switched off and that the system is at atmospheric pressure.
2. Disconnect the tubes from the condenser and drain coolant safely into a storage container.

10.1.3 Remove the heating bath



WARNING

Hot surfaces!



Scalding and burns.
→ Cool the heating bath.



Remove the heating bath

- Remove the heating bath in reverse sequence of the assembly (see chapter 4.4.1).

10.2 Storage

Evaporator

Where?

- The unit may be stored in a dry location.

How?

- Store the unit in the original packaging (only possible with the transportation protection device attached).
- Close the packaging with adhesive tape.

Glassware set

Where?

- The glassware set may be stored in a dry location.

How?

- Empty and clean the glassware set.
- Store the glassware set in the original packaging.
- Close the packaging with adhesive tape.

10.3 Disposal

Disposal

- Properly dispose of the unit according to the valid national and legal regulations pertaining to disposal of used laboratory equipment.

11 Accessories, spare parts

11.1 Glass devices

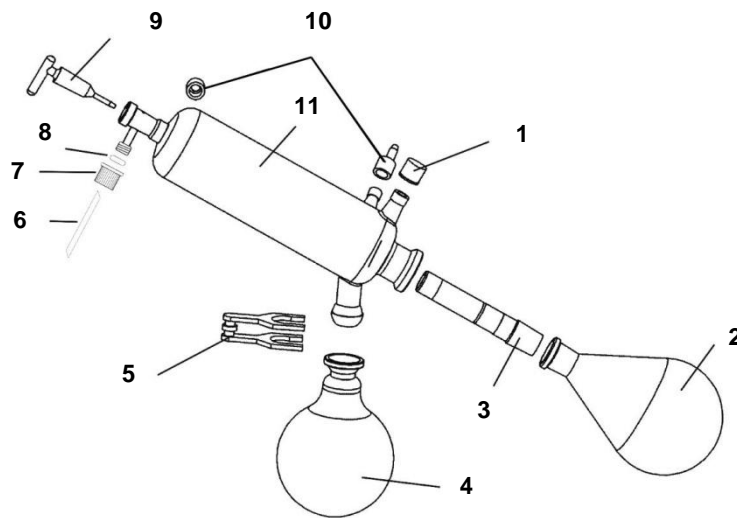

Figure 11–1: Glassware set G1

Order description	Position	Order No.	Piece at delivery
Threaded fitting GL 18	1	23-09-03-01-24	1
Evaporator flask 1,000 ml, NS 29/32	2	514-74000-00	1
Evaporator flask 1,000 ml, NS 24/40	2	514-74000-05	(1)
Vapor tube NS 29 / 32	3	514-00000-01	1
Vapor tube NS 24 / 40	3	514-00020-03	(1)
Receiving flask 1000 ml, S 35/20	4	514-84000-00	1
Receiving flask 1000 ml, S 35/20, plastic coated	4	514-84000-02	(1)
Condenser clamp S 35/20	5	515-42000-00	1
Inlet tube (PTFE-) 3.5/4.5x600	6	23-30-01-04-72	1
Threaded fitting GL10 red	7	23-30-01-04-69	1
Seal O-ring 3.2x2.5	8	23-08-06-03-26	1
Inlet pipe (stopcock)	9	514-51000-00	1
Threaded fitting GL 14	10	23-09-03-01-27	3
Connector for the threaded fitting GL 14	10	11-300-005-22	3
Condenser G1	11	514-00100-00	1
Condenser G1B, plastic coated	11	514-00110-00	(1)

Table 11-1: Glassware set G1

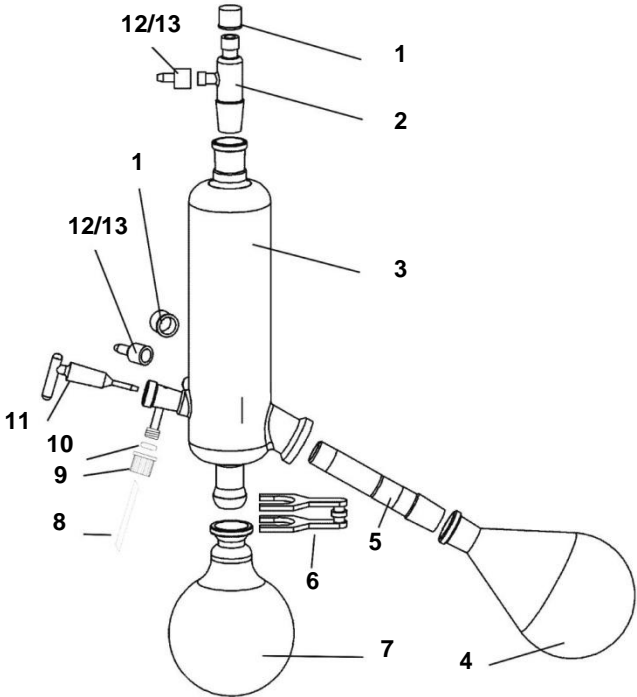

Figure 11–2: Glassware set G3

Order description	Position	Order No.	Piece at delivery
Threaded fitting GL 18	1	23-09-03-01-24	2
Vacuum fitting NS 29 / 32	2	514-00001-00	1
Condenser G3	3	514-00300-00	1
Condenser G3B, plastic coated	3	514-00310-00	(1)
Evaporator flask 1,000 ml, NS 29/32	4	514-74000-00	1
Evaporator flask 1,000 ml, NS 24/40	4	514-74000-05	(1)
Vapor tube NS 29 / 32	5	514-00000-01	1
Vapor tube NS 24 / 40	5	514-00020-03	(1)
Condenser clamp S 35/20	6	515-42000-00	1
Receiving flask 1000 ml, S 35/20	7	514-84000-00	1
Receiving flask 1000 ml, S 35/20, plastic coated	7	514-84000-02	(1)
Inlet tube (PTFE-) 3.5/4.5x600	8	23-30-01-04-72	1
Threaded fitting GL10 red	9	23-30-01-04-69	1
Seal O-ring 3.2x2.5	10	23-08-06-03-26	1
Inlet pipe (stopcock)	11	514-51000-00	1
Threaded fitting GL 14	12	23-09-03-01-27	3
Connector for the threaded fitting GL 14	13	11-300-005-22	3
Condenser mounting		569-00050-00	1

Table 11-2: Glassware set G3

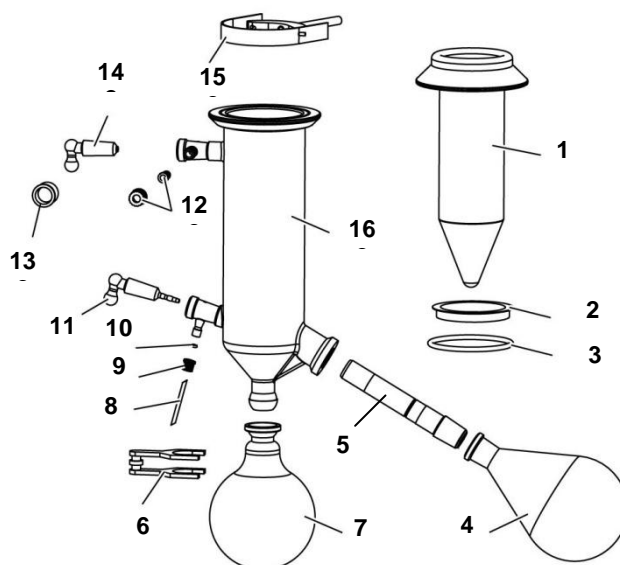

Figure 11–3: Glassware set G5

Order description	Position	Order No.	Piece at delivery
Insert cold trap	1	514-00501-00	1
Centering ring	2	23-30-01-04-88	1
Seal G5 (silicone)	3	23-30-01-01-88	(1)
Gasket G5	3	23-30-01-01-39	1
Evaporator flask 1,000 ml, NS 29/32	4	514-74000-00	1
Evaporator flask 1,000 ml, NS 24/40	4	514-74000-05	(1)
Vapor tube NS 29 / 32	5	514-00000-01	1
Vapor tube NS 24 / 40	5	514-00020-03	(1)
Condenser clamp S 35/20	6	515-42000-00	1
Receiving flask 1000 ml, S 35/20	7	514-84000-00	1
Receiving flask 1000 ml, S 35/20, plastic coated	7	514-84000-04	(1)
Inlet tube (PTFE-) 3.5/4.5x600	8	23-30-01-04-72	1
Threaded fitting GL10 red	9	23-30-01-04-69	1
Seal O-ring 3.2x2.5	10	23-08-06-03-26	1
Inlet pipe (stopcock)	11	514-51000-00	1
Threaded fitting GL 14	12	23-09-03-01-27	2
Connector for the threaded fitting GL 14	12	11-300-005-22	2
Threaded fitting GL 18	13	23-09-03-01-24	1
Stopper NS 19 / 38 (stopcock)	14	15-003-003-24	1
Holder, complete	15	569-00051-00	1
Liner cold trap	16	514-00500-00	1
Liner cold trap, plastic coated	16	514-00510-01	(1)

Table 11-3: Glassware set G5

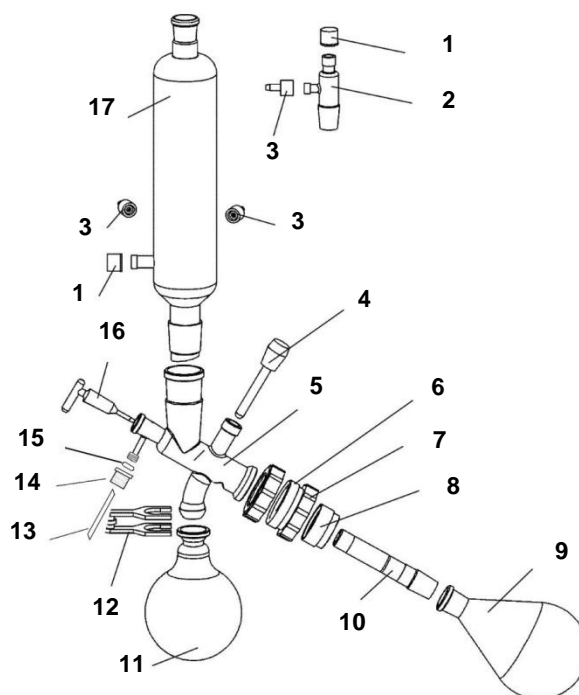

Figure 11–4: Glassware set G6

Order description	Position	Order No.	Piece at delivery
Threaded fitting GL 18	1	23-09-03-01-24	2
Vacuum fitting NS 29 / 32	2	514-00001-00	1
Threaded fitting GL 14	3	23-09-03-01-27	3
Connector for the threaded fitting GL 14	3	11-300-005-22	3
Valve	4	514-48000-00	1
Center piece G6	5	514-00601-00	1
Center piece G6B, plastic coated	5	514-00611-00	(1)
G6 threaded coupling	6	515-62000-00	1
Gasket G6	7	23-30-01-01-35	1
Intermediate part G6	8	22-30-01-05-02	1
Evaporator flask 1,000 ml, NS 29/32	9	514-74000-00	1
Evaporator flask 1,000 ml, NS 24/40	9	514-74000-05	(1)
Vapor tube NS 29 / 32 G6	10	514-00000-05	1
Vapor tube NS 24 / 40 G6	10	514-00020-06	(1)
Receiving flask 1000 ml, S 35/20	11	514-84000-00	1
Receiving flask 1000 ml, S 35/20, plastic coated	11	514-84000-02	(1)
Condenser clamp S 35/20	12	515-42000-00	1
Inlet tube (PTFE-) 3.5/4.5x600	13	23-30-01-04-72	1
Threaded fitting GL10 red	14	23-30-01-04-69	1
Seal O-ring 3.2x2.5	15	23-08-06-03-26	1
Inlet pipe (stopcock)	16	514-51000-00	1
Condenser G6	17	514-23000-00	1

Condenser G6B, plastic coated	17	514-23000-02	(1)
Condenser mounting		569-00050-00	1

Table 11-4: Glassware set G6

11.2 Accessories

Order description	Order No.	Order No.	Comments
	230 V 50/60 Hz	115 V 50/60 Hz	
Protective hood	569-00010-00		
Protective shield	569-00020-00		
Vapor temperature sensor	569-00030-00		
Temperature sensor Auto _{accurate} sensor	569-00040-00		
Vacuum pump ROTAVAC valve control	591-00130-00	591-00130-01	
Condensate cooler for ROTAVAC valve control	591-00081-00		
Vacuum pump ROTAVAC valve tec	591-00160-00	591-00160-01	
Condensate cooler for ROTAVAC valve tec	591-00083-00		
Vacuum pump ROTAVAC vario control	591-00141-00	591-00141-01	
Condensate cooler for ROTAVAC vario control	591-00084-00		
Vacuum pump ROTAVAC vario tec	591-00171-00	591-00171-01	
Condensate cooler for ROTAVAC vario tec	591-00084-00		
Vacuum box	569-00100-00		
Vacuum controller VAC control automatic	569-00340-00	569-00340-01	
Vacuum switch box for 3 consumers	569-00400-00	569-00400-01	
Vacuum valve	569-00060-00		
Woulff bottle	569-00070-00		
Vacuum controller, manual	591-26000-00		
Tube set	591-35000-00		
Heating bath liquid (up to 180 °C)	515-31000-00		
PTFE 26 Vacuum seal	23-30-01-01-30		
Clamping sleeve	23-30-01-05-31		
Transportation safety device	11-300-006-28		

Table 11-5: Accessories

12 Appendix

12.1 Technical data

Basic Device	Basis Hei-VAP Value	Basis Hei-VAP HL.	Basis Hei-VAP ML	Basis Hei-VAP HL	Basis Hei-VAP ML
Dimensions (WxDxH) of drive unit in the lowest position without a glassware set ****	393 x 449 x 427 mm	393 x 449 x 427 mm	393 x 411 x 427 mm	393 x 449 x 427 mm	393 x 411 x 427 mm
Connected load	1400 W				
Connected voltage	230 V / 50/60 Hz or 115 V / 50/60 Hz				
Drive unit	EC motor with electronic speed control				
Drive unit of lift	Manual	Manual	Motor	Manual	Motor
Speed range	10 – 280 min ⁻¹				
Weight incl. heating bath without glassware set	16 kg	16 kg	16 kg	17 kg	17 kg
Lifting speed	manual	manual	approx. 40 mm/s	manual	approx. 40 mm/s
Length of stroke	155 mm				
Cooling surface	1,200 cm ²				
Panel	Bedienpanel Value or Bedienpanel Collegiate	Bedienpanel Advantage-HL	Bedienpanel Advantage-ML	Bedienpanel Precision HL	Bedienpanel Precision ML
Connected load	24V dc				
Connected voltage	1W			2W	
display	Scale	3.5" LCD screen	3.5" LCD screen	4.3" LCD color screen	4.3" LCD color screen
Control panel					
– Lift	-	-	yes	-	yes
– Start Rotation	yes	yes	yes	yes	yes
– Start Vakuum	-	-	-	yes	yes
– Start Heizbad	yes	yes	yes	yes	yes
– Start Timer	-	yes	yes	yes	yes
Heating Bath	Heizbad Hei-VAP				
Heating capacity	1300 W				
Diameter of heating bath	255 mm				
Heating bath material	V4A (1.4404)				
Heating bath temperature range	20–210 °C				
Heating bath control accuracy	±1 K				
Heating bath temperature control	electronic/digital				

Degree of protection	IP 20				
Airborne sound level	Clearly lower than 85 db(A)				
Permissible ambient conditions	5 – 31 °C at 80 % relative humidity 32 – 40 °C decreasing linear to a max. rel. humidity of 50% 0 - 2000m absolute altitude Pollution Degree 2 Installation Category II				
Connected voltage *** $\pm 10\%$	230 V / 50/60 Hz	230 V / 50/60 Hz	230 V / 50/60 Hz	230 V / 50/60 Hz	230 V / 50/60 Hz
	115 V / 50/60 Hz	115 V / 50/60 Hz	115 V / 50/60 Hz	115 V / 50/60 Hz	115 V / 50/60 Hz
Evaporation rate (L/h) ΔT^* 20/40 °C					
– Toluene	4,1 / 8,2	4,1 / 8,2	4,1 / 8,2	4,1 / 8,2	4,1 / 8,2
– Acetone	2,4 / 4,7	2,4 / 4,7	2,4 / 4,7	2,4 / 4,7	2,4 / 4,7
– Ethanol	1,6 / 3,2	1,6 / 3,2	1,6 / 3,2	1,6 / 3,2	1,6 / 3,2
– Water	0,5 / 1,0	0,5 / 1,0	0,5 / 1,0	0,5 / 1,0	0,5 / 1,0

Table 12-1: Technical data

* ΔT = Difference between the heating bath temperature and the boiling temperature

** Only possible in conjunction with vacuum systems

*** Standard 230 V/50/60 Hz: other connecting voltages upon request

**** Ready to connect including the power plug

Unit configuration

Hei-VAP Value:

- With manual control valve for limiting the vacuum and a Rotovac valve vacuum pump
 - Manual vacuum controller for limiting the vacuum with the ROTAVAC valve control
 - Manual vacuum controller for limiting the vacuum with the ROTAVAC valve tec
- Without a controller with a Rotovac valve vacuum pump
 - ROTAVAC valve control or ROTAVAC valve tec
- With a controller and valve-controlled vacuum pump
 - Vac control automatic with vacuum valve (optional Woulff bottle) and ROTAVAC valve control
 - Vac control automatic with vacuum valve (optional Woulff bottle) and ROTAVAC valve tec
- With controller and vacuum
 - Valve Control automatic with vacuum valve (optional Woulff bottle) and vacuum
- With manual control valve and vacuum
 - Manual vacuum controller for limiting the vacuum with vacuum

Hei-VAP Advantage:

- Without a controller with a Rotovac valve vacuum pump
 - ROTAVAC valve control or ROTAVAC valve tec
- With a controller and valve-controlled vacuum pump
 - Vac control automatic with vacuum valve (optional Woulff bottle) and ROTAVAC valve control
 - Vac control automatic with vacuum valve (optional Woulff bottle) and ROTAVAC valve tec
- With controller and vacuum
 - Valve Control automatic with vacuum valve (optional Woulff bottle) and vacuum
- With vacuum
 - vacuum only

Hei-VAP Precision:

- Rotary evaporator Hei-VAP with valve-controlled vacuum pump
 - Vacuum valve (optional Woulff bottle) and ROTAVAC valve control
 - with vacuum valve (optional Woulff bottle) and ROTAVAC valve tec
- Rotary evaporator Hei-VAP with speed-controlled vacuum pump
 - with ROTAVAC vario control
 - with ROTAVAC vario tec
- Rotary evaporator Hei-VAP with vacuum
 - with vacuum valve (optional Woulff bottle) and vacuum
- Expanded function of the above listed configurations
 - Function "Auto_{accurate} " with Auto_{accurate} sensor
 - Display of the vapor temperature with boiling temperature sensor

12.2 Technical data o the vacuum box Hei-VAP

	Order No. 569-00100-00
Connected voltage	24V DC
Connected load	3 W

Table 12-2: Technical data o the vacuum box

12.3 Solvent data

The graph shows the relationship between the pressure and boiling temperature of a selection of solvents.



The temperature difference between the vapor temperature and the cooling medium should be at 20 K to result in sufficient condensation.

The temperature difference between the heating bath and vapor temperature should be at 20 K to result in a sufficient Distillation rate (dT).

i.e.: Set a vacuum for a boiling point at 40 °C, set the heating bath temperature at 60 °C.

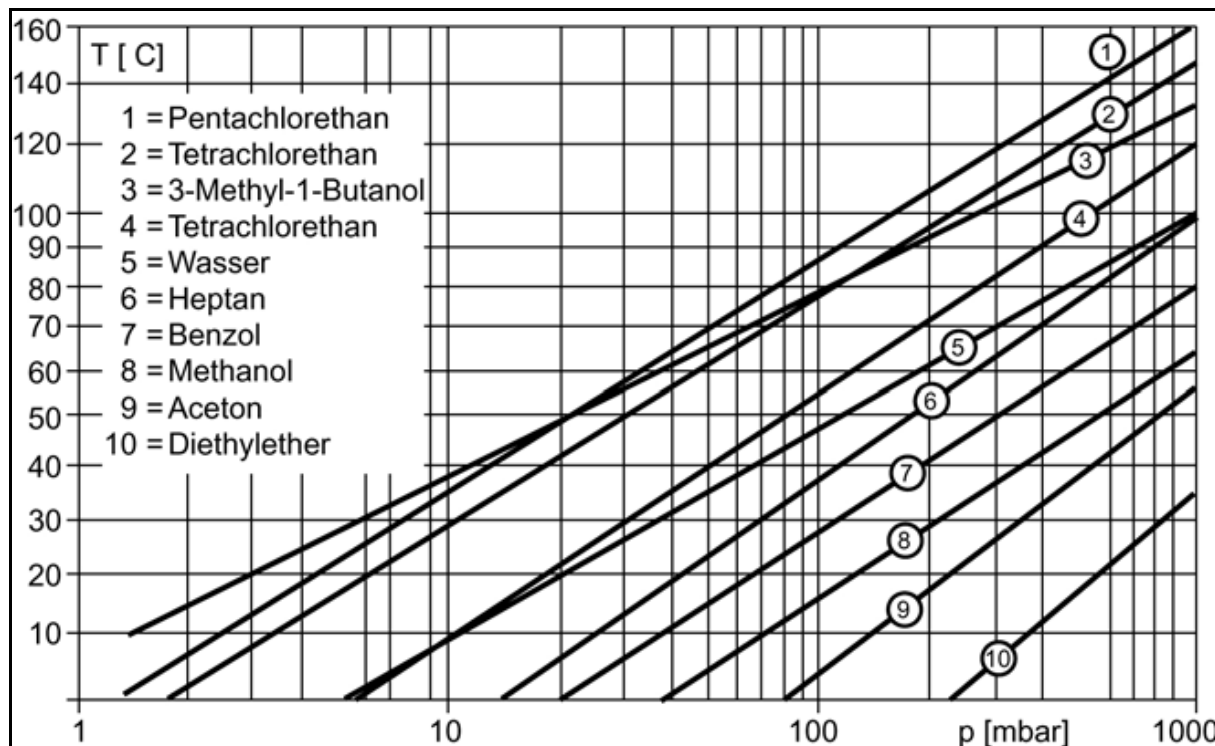

Figure 12–1: Graph

Torr to mbar conversion: [mmHg] \approx 3/4 [mbar]

Solvent data

Solvents	Total formula	MW [g/mol]	Boiling point [°C]	Δh_{vap} [J/g]	Vacuum for a boiling point at 40 °C	
					[mbar]	[mm(Hg)]
Acetone	C ₃ H ₆ O	58,08	56,5	550	556	387
Acetonitrile	C ₂ H ₃ N	41,05	81,8	833	230	173
Benzene	C ₆ H ₆	78,11	80,1	549	236	177
n-butanol (butyl alcohol)	C ₄ H ₁₀ O	74,12	117,5	619	25	19
tert.-butanol (tert-butyl alcohol)	C ₄ H ₁₀ O	74,12	82,9	588	130	98
2-Butanone (methyl ethyl ketone)	C ₄ H ₈ O	72,11	79,6	473	243	182
Chlorobenzene	C ₆ H ₅ Cl	112,60	132,2	375	36	27
Cyclohexane	C ₆ H ₁₂	84,16	80,7	389	235	176
1.2 Dichloroethane	C ₂ H ₄ Cl ₂	98,96	82,4	336	210	158

Solvents	Total formula	MW [g/mol]	Boiling point [°C]	Δh_{vap} [J/g]	Vacuum for a boiling point at 40 °C	
					[mbar]	[mm(Hg)]
1,2 Dichloroethylene (cis)	C ₂ H ₂ Cl ₂	96,94	59,0	320	479	134
1,2 Dichloroethylene (trans)	C ₂ H ₂ Cl ₂	96,94	47,8	313	751	563
Dichloromethane (methylene chloride)	CH ₂ Cl ₂	84,93	40,7	373	atm.	atm.
Diethyl ether	C ₄ H ₁₀ O	74,12	34,6	392	atm.	atm.
Diisopropyl ether	C ₆ H ₁₄ O	102,20	67,5	318	375	281
Dimethylformamide	C ₃ H ₇ NO	73,09	153,0		11	8
1,4-Dioxane	C ₄ H ₈ O ₂	88,11	101,1	406	107	80
Ethanol	C ₂ H ₆ O	46,07	78,4	879	175	131
Ethylacetate	C ₄ H ₈ O ₂	88,11	77,1	394	240	180
Heptane	C ₇ H ₁₆	85,09	98,4	439	120	90
Hexane	C ₆ H ₁₄	86,18	68,7	370	335	251
Methanol	CH ₄ O	32,04	64,7	1225	337	253
3-Methyl-1-butanol (Isoamyl alcohol)	C ₅ H ₁₂ O	88,15	130,6	593	14	11
Pentachlorinated Ethane	C ₂ HCl ₅	202,30	160,5	203	13	10
Pentane	C ₅ H ₁₂	72,15	36,1	382	atm.	atm.
n-Pentanol (amyl alcohol)	C ₅ H ₁₂ O	88,15	137,8	593	11	8
1-Propanol (n-propyl alcohol)	C ₃ H ₈ O	60,10	97,8	787	67	50
2-Propanol (isopropyl alcohol)	C ₃ H ₈ O	60,10	82,5	701	137	103
1,1,2,2-Tetrachloroethane	C ₂ H ₂ Cl ₄	167,90	145,9	247	35	26
Tetrachloroethylene	C ₂ Cl ₄	165,80	120,8	233	53	40
Tetrachloromethane (carbon tetrachloride)	CCl ₄	153,80	76,7	225	271	203
Tetrahydrofuran (THF)	C ₄ H ₈ O	72,11	66,0	–	357	268
Toluene	C ₇ H ₈	92,14	110,6	425	77	58
1,1,1-Trichloroethane	C ₂ H ₃ Cl ₃	133,40	74,1	251	300	225
Trichloroethylene	C ₂ HCl ₃	131,40	86,7	265	183	137
Trichloromethane (chloroform)	CHCl ₃	119,40	61,3	263	474	356
Water	H ₂ O	18,02	100,0	2259	72	54
Xylene (isomers mixture)	C ₈ H ₁₀	106,20	137–143	390	25	19

Table 12-3: Solvent data

12.4 EC Declaration of Conformity

We, Heidolph Instruments GmbH & Co. KG,

Heidolph Instruments GmbH & Co. KG

Vertrieb Labortechnik

Walpersdorfer Str. 12

91126 Schwabach / Germany

declare that rotary evaporators of the Hei-VAP series for:

- distillation, evaporation
- purification of chemicals, substances, mixtures and preparations
- processing reaction batches
- drying of powder

Construction year: since 2009

Serial number: see model plate

Component number: see model plate

comply with the following standards and standardized documents:

EMV guideline 2004/108/EG:

- | | |
|-------------------------------------|--|
| • EN 61326-1:2006 + correction 2006 | • EN 61000-3-2:2006 |
| • EN 61326-2-1:2006 | • EN 61000-3-3: 1995 + 2006 + A1:2001 + A2: 2005 |
| • EN 61326-2-2:2006 | • EN 61000-4-2:1995 +A1:1998+A2:2001 |
| • EN 61326-2-3:2006 | • EN 61000-4-3:2006 +A1:2008 |
| • EN 61326-2-4:2007 | • EN 61000-4-4:2004 |
| • EN 61326-2-5:2007 | • EN 61000-4-5:2006 |
| • EN 61326-2-6:2007 | • EN 61000-4-6:2007 + corrigendum 2007 |
| • EN 61326-3-1:2008 | • EN 61000-4-11:2004 |
| • EN 61326-3-2:2008 | |
| | • EN 60529: 1991 + A1 : 2000 |

Low Voltage Directive:

2006/95/EG

- EN 61010-1:2001 + first correction: 2002 + second correction 2002
- EN 61010-2-010:2003

Airborne noise emission:

EN ISO 3744:1995 and EN ISO 2151:2008

This declaration is void if modifications were performed on the unit without our prior consent.

The declaration of conformity was created according to DIN EN ISO/IEC 17050-1 "General criteria for supplier's declaration of conformity".

Date: 18.07.2009

Signature:



Name of the undersigned:

S. Richter

12.5 Warranty Statement



Heidolph Instruments guarantees a warranty of three years for the products described here (except glass and wear parts) if you are registering with the enclosed warranty card or via the Internet (www.heidolph.com). The warranty begins with the registration. The serial number of the unit is valid without the registration. This warranty covers material and manufacturing defects. Transport damages are excluded.

In the event of a warranty claim, please contact Heidolph Instruments (Tel: (+49) 9122 - 9920-69) or your local Heidolph Instruments dealer.

If it is a material or manufacturing defect, the unit will be repaired or replaced free of charge within the scope of the warranty.

Heidolph Instruments will not assume any guarantees for damages due to improper treatment.

Heidolph Instruments GmbH & Co. KG

Vertrieb Labortechnik

Walpersdorfer Str. 12

91126 Schwabach / Germany

12.6 Declaration of non-objection

Copy and mail / fax this declaration in the event of repairs to Heidolph Instruments GmbH & Co KG (see Chapter 9.4).

1. Information regarding the unit

Model description _____
 Part number _____
 Reason for submission _____

2. Was the device cleaned, if necessary, decontaminated / disinfected?

Yes _____ No _____

3. Is the unit in a condition that poses no health risks to repair personnel?

Yes _____ No _____

 If no, what substances was the unit in contact?

4. Information regarding the sender

Last name, first name _____
 Company _____
 Department _____
 Street _____
 Postal code / city _____
 Country _____
 Telephone _____
 E-mail _____

5. Legally binding declaration

 The client is aware that he is liable to the contractor for damages caused by incomplete and incorrect information.

Date _____
 Signature _____

01-005-004-79

24.08.2009

© Heidolph Instruments GmbH & Co. KG

Technische Änderungen sind ohne vorherige Ankündigung vorbehalten.

Technical changes reserved. Publication not mandatory.

Sous réserve de modifications techniques sans notification préalable.

Nos reservamos el derecho de introducir modificaciones técnicas sin previo aviso.

Ci si riserva il diritto di apportare modifiche tecniche senza preavviso.
